

CVS
CONTROLS

SY Series Scotch Yoke Pneumatic Actuators

- Suitable for use on low temperature to -40°C to 80°C. Optional ranges of -50°C to 80°C, and 20°C to 200°C
- Suitable for use in severe environments such as chemical & petroleum and offshore industries
- Available for double acting and spring return and the air pressure from 3Bar to 6Bar
- Available for bi-directional travel stop adjustment at $\pm 6^\circ$

About SY Actuator

CVS SY series scotch yoke pneumatic actuators are specifically designed for use with quarterturn valves. The large output torque range offered by CVS Controls ensures that our actuators match the operational characteristics of plug, ball or butterfly valves; or any device requiring precise and reliable 90° rotary motion. The CVS Series SY Scotch yoke actuators offer large output torque range. For the spring return version, the output torque range from 200Nm to 170,000Nm. For the double acting version, the output torque range from 100Nm to 250,000Nm.

Minimum Maintenance

Every CVS SY actuator is built to provide long and efficient service with minimum maintenance. The design, engineering and materials used in their construction ensure optimum performance even in the harshest of environments.

Manual Override Options

A dependable manual override facility is an important part to many valve/actuator applications. CVS Controls has a variety of override options available to meet virtually any requirement.

Available options include open or closed screw manual override and hydraulic override.

Robust and Lightweight Design

Totally enclosed weatherproof centrebody fabricated in carbon steel or ductile iron provide an excellent strength to weight ratio. The piston and yoke mechanism has a high advantage torque output.

Extensive Product Range

CVS Controls offers an extensive line of fluid power valve actuators. Products include low and high pressure pneumatic, hydraulic and pneumatic-hydraulic actuators and Spring-Diaphragm actuators.

Complete Control Solutions

Air Control component packages are a part of any actuator/valve installation. CVS Controls has extensive experience in the design and assembly of all types of air control systems to satisfy any customer requirement for on/off, control or ESD service.

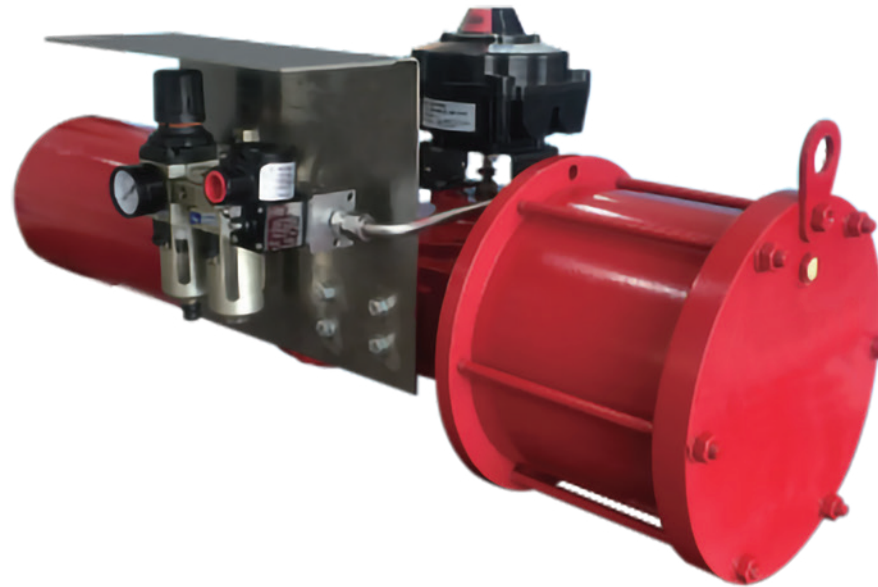

ISO5211 and Namur Mounting

The CVS SY series actuator's connections are standard ISO5211 interface to valve and Namur interface to limit switch box or valve positioners.

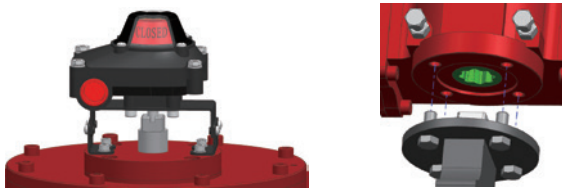

Stroke

The CVS SY yoke mechanism is fitted with mechanical end stops (open or closed positions) to ensure adjustable range of $\pm 6^\circ$.

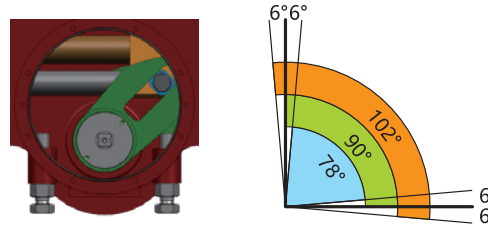

Water ingress protection

O-ring and seals (NBR for standard and PTFE for extreme cold) are fitted on bodys, caps, cylinders and each connection to ensure water ingress protection.



Operating Conditions

Working media is 3 - 6 bar pressure air which is less than 40um filtered, dried and lubricated. The Series SY actuator is suitable for use in high temperature and extreme cold environments.



Corrosion Resistant

CVS SY actuators are coated to resist severe weather, chemical and petroleum environments. The inner surface of cylinder is coated by PTFE, enhance corrosion resistant and is self lubricating.



ASY in extreme cold environment

In extreme cold environment applications, PTFE is used for seals and low temperature pressure vessel steel (09MnNiDR) is used for each module. The body will be welded by 09MnNiDR.

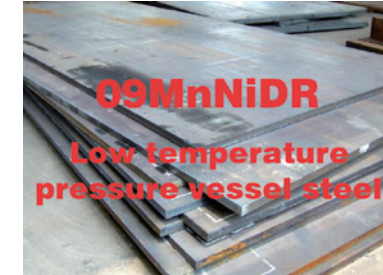

Actuator Operating Principle

In a CVS SY double acting actuator, one or two pneumatic cylinders are fitted to one or each side, and the actuator is operated by air pressure. (*maximum air supply pressure is 116 psi - Max Casing Pressure is 140 psi)

In the spring return actuator, one side is fitted with pneumatic cylinder while the other side is fitted with a spring cartridge for emergency shut down (ESD) applications. The actuator is operated by pressure air in one position (open or closed) and by spring energy in another position (closed or open). The following is the operating principle.

Air to open position

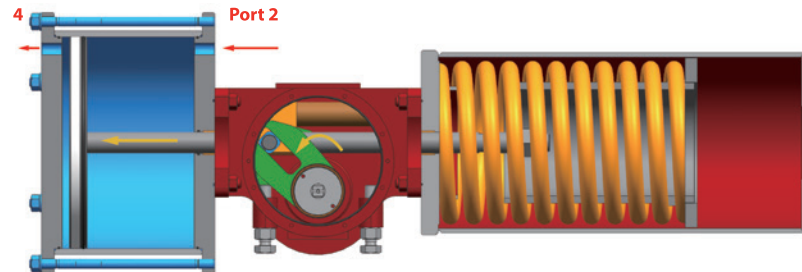

Air to port 2 forces the piston towards the left, causing the spring to be compressed and the yoke turns counterclockwise (to open the valve) while air is exhausted from port 4 (refer to the photograph above).

Spring return to closed position

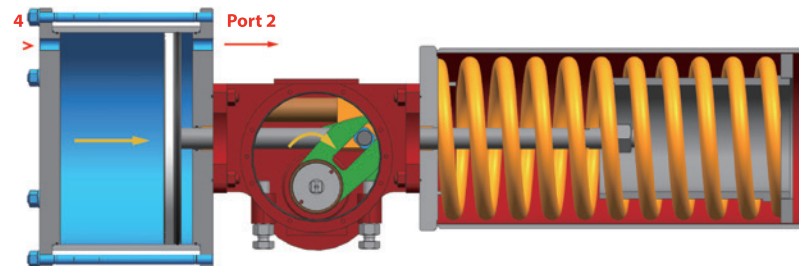

Loss of air pressure on port 2, the stored energy in the spring forces the piston towards the right and the yoke turns clockwise (to close the valve) while air is exhausted from port 2 and port 4. (refer to the photograph above).

Modular Structure and Application

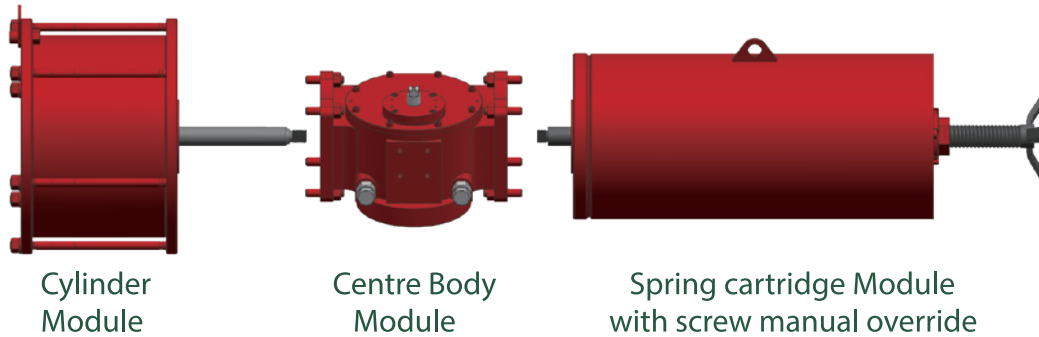

Flexible Modular Design

CVS SY series actuator share modular construction design. The centre body is available in ten sizes. A pneumatic or hydraulic cylinder can be attached to either or both sides. A spring cartridge can also be fitted to either side for ESD (emergency shut down) applications.

Field Serviceable

The modules are removable and interchangeable while mounted to operate the valve used in certain specific applications. Note that only same size of modular unit can be interchanged.

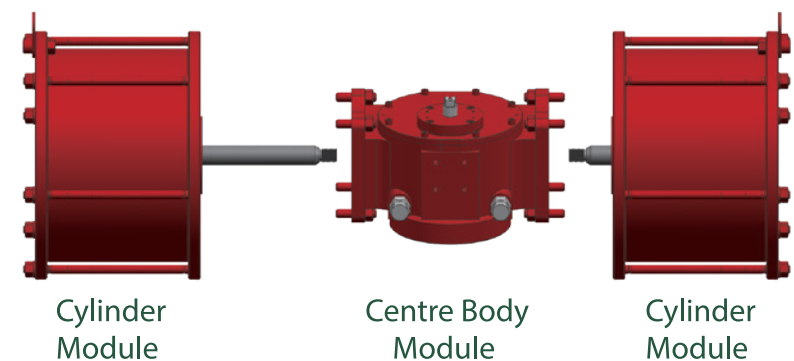
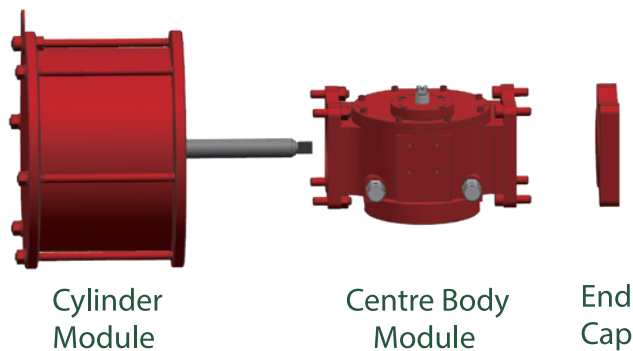
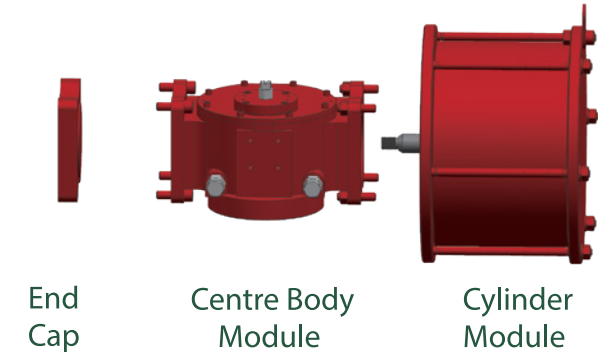
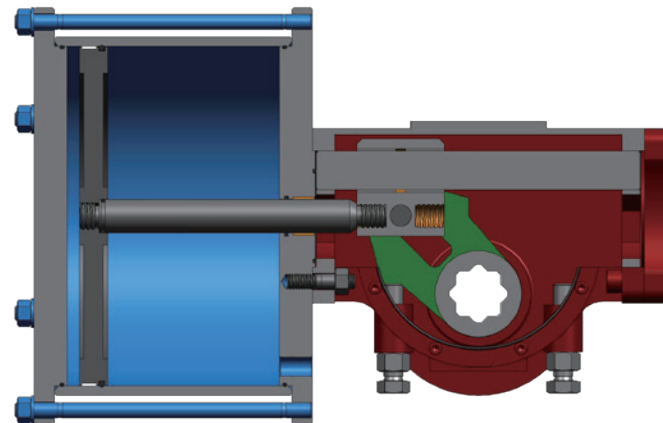

Parts and Materials

* Material for choice

The carbon steels and NBR O-rings are for standard temperature application. For low temperature application, the high strength low alloy steel (Q345E) and LNBR O-rings will be used. For extreme cold application, low temperature pressure vessel steel (09MnNiDR) and PTFE O-rings will be used.

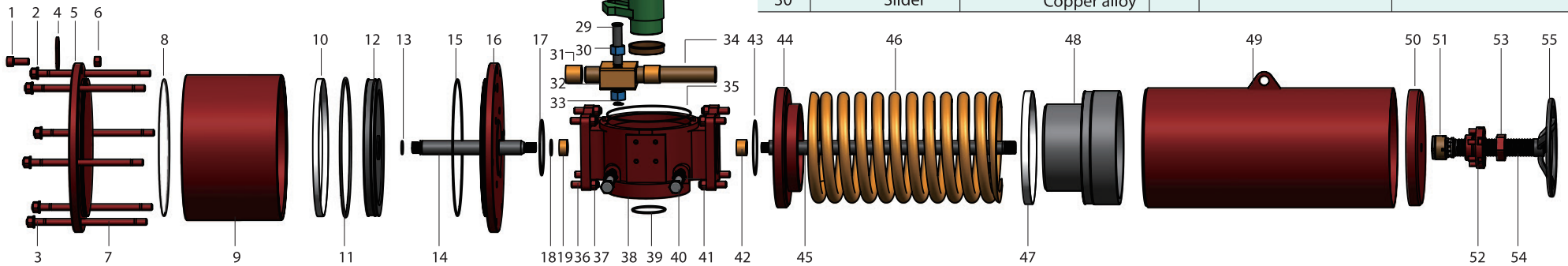

Body Module

	Name	Material		Name	Material
20	Bolt	Carbon steel	31	Bushing	Alloy
21	Gland	Stainless steel	32	Gulde	Carbon steel
22	O-ring	NBR*	33	Snap spring	65Mn
23	Namur indicator	Stainless steel	34	Guide	Carbon steel
			35	O-ring	NBR*
24	Bolt	Carbon steel	36	Stud	Carbon steel
25	Lid	Ductile Iron	37	Nut	Carbon steel
26	O-ring	NBR*	38	Body	Ductile Iron
27	Bushing	Alloy	39	O-ring	NBR*
28	Yoke	Carbon steel*	40	Regulat screw	Carbon steel
29	Pin	Alloy steel	41	Lock nut	Carbon steel
30	Silder	Copper alloy			

Cylinder Module

	Name	Material		Name	Material
1	Bolt	Carbon steel*	11	O-ring	NBR*
2	Nut	Carbon steel	12	Piston	Carbon steel*
3	Gasket	Carbon steel	13	O-ring	NBR*
4	Lug	Carbon steel	14	Push rod	Carbon steel
5	Rear end	Carbon steel*	15	O-ring	NBR*
6	Nut	Carbon steel	16	Front end	Carbon steel*
7	Screw	Carbon steel	17	O-ring	NBR*
8	O-ring	NBR*	18	O-ring	NBR*
9	Cylinder barrel	Carbon steel*	19	Bushing	Alloy
10	Guidance tape	PTFE			

Spring Module

	Name	Material
42	Bushing	Alloy
43	O-ring	NBR*
44	Spring cover	Carbon steel*
45	Spring shaft	Carbon steel
46	Spring	Spring steel*
47	Guidance tape	PTFE
48	Spring seat	Carbon steel*
49	Spring body	Carbon steel*
50	End cover	Carbon steel*
51	Coupling	Carbon steel
52	Lock device	Carbon steel
53	Nut	Carbon steel
54	Wirerod	Carbon steel
55	Handwheel	Cast rion

Ordering Guide of SY Actuators

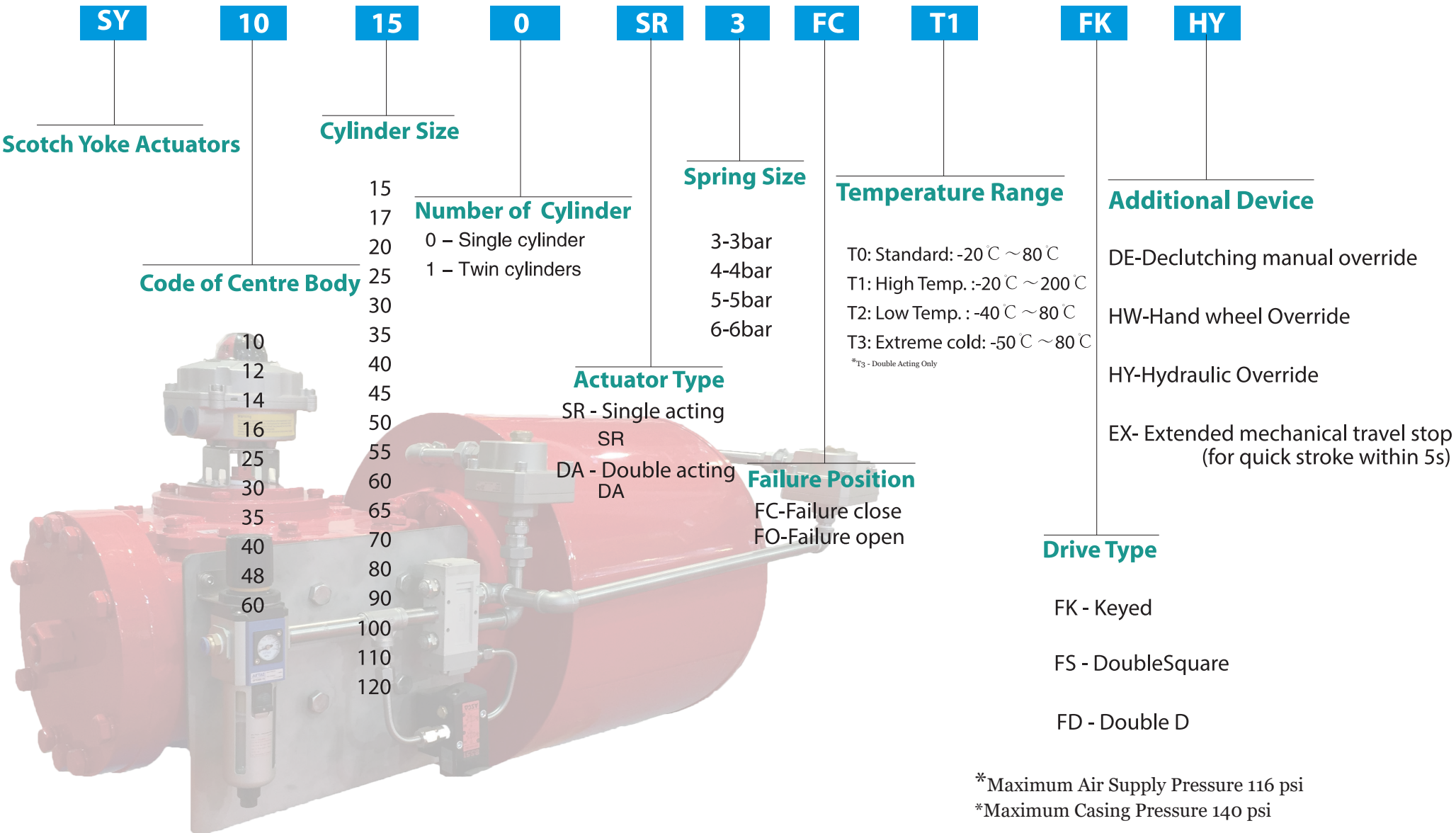

*Maximum Air Supply Pressure 116 psi
*Maximum Casing Pressure 140 psi

Output Torque

Output Torque of SY Series Actuator with Spring Return (SR)

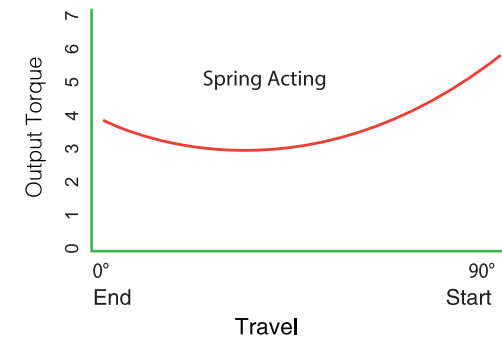
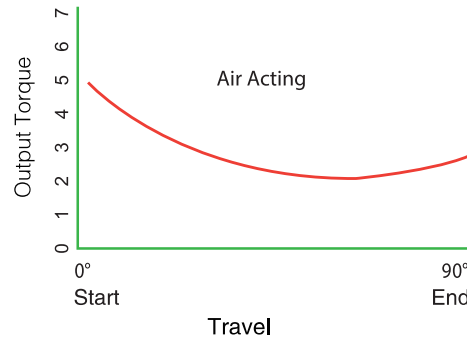
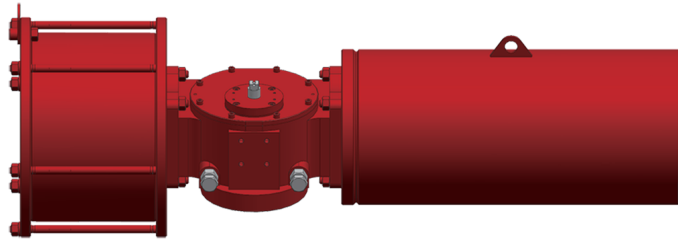

Unit:Nm

Model	3Bar						4Bar						5.5Bar						6Bar					
	Spring Acting			Air Acting			Spring Acting			Air Acting			Spring Acting			Air Acting			Spring Acting			Air Acting		
	Start	Run	End	Start	Run	End	Start	Run	End	Start	Run	End	Start	Run	End	Start	Run	End	Start	Run	End	Start	Run	End
SY10-150SR	191	93	120	203	95	127	255	124	159	271	127	170	319	156	199	361	127	241	382	187	239	407	191	254
SY10-170SR	245	120	154	261	123	163	328	160	205	349	163	218	410	200	256	463	164	309	491	240	307	522	245	327
SY12-170SR	307	150	192	327	153	204	410	200	256	436	204	272	512	250	320	582	270	390	614	300	384	653	306	409
SY12-200SR	425	207	266	452	212	283	567	276	354	603	283	377	709	346	443	801	3444	535	850	415	532	904	424	565
SY14-200SR	510	249	319	543	254	339	680	332	425	724	339	452	850	415	532	996	518	678	1020	498	638	1085	509	679
SY14-250SR	797	389	498	848	398	530	1063	518	664	1131	530	707	1329	648	831	1558	801	1060	1594	778	997	1696	795	1060
SY14-300SR	1148	560	718	1221	573	763	1531	746	957	1629	763	1018	1914	933	1196	2304	1217	1586	2296	1120	1435	2442	1145	1527
SY16-250SR	996	486	623	1060	497	663	1329	648	831	1414	663	884	1661	810	1038	1973	1013	1350	1993	972	1246	2120	994	1325
SY16-300SR	1435	700	897	1527	716	954	1914	933	1196	2036	954	1272	2392	1166	1495	2783	1459	1886	2870	1400	1794	3053	1431	1909
SY16-350SR	1953	952	1221	2078	974	1299	2605	1270	1628	2771	1299	1732	3256	1587	2035	3945	1916	2724	3906	1905	2442	4156	1948	2598
SY25-350SR	2344	1143	1465	2494	1169	1559	3126	1524	1953	3325	1559	2078	3907	1905	2442	4762	2382	3297	4688	2286	2930	4987	2338	3117
SY25-400SR	3061	1493	1914	3257	1527	2036	4082	1991	2551	4343	2036	2714	5103	2488	3189	5955	3110	4041	6123	2986	3827	6514	3054	4072
SY25-450SR	3875	1889	2422	4122	1932	2576	5167	2519	3229	5497	2576	3435	6458	3149	4037	7777	3800	5356	7750	3779	4844	8244	3865	5153
SY30-450SR	4305	2099	2691	4580	2147	2863	5741	2799	3588	6107	2863	3817	7176	3499	4485	9658	4374	6967	8611	4199	5382	9160	4294	5726
SY30-500SR	5315	2592	3322	5655	2651	3534	7087	3456	4430	7540	3534	4712	8859	4320	5537	11917	5400	8595	10631	5184	6644	11309	5301	7069

*maximum air supply pressure is 116 psi

Output Torque

Output Torque of SY Series Actuator with Spring Return (SR)

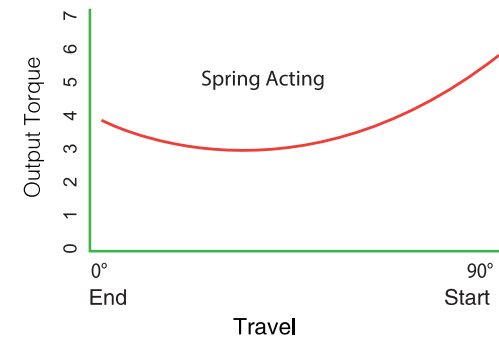
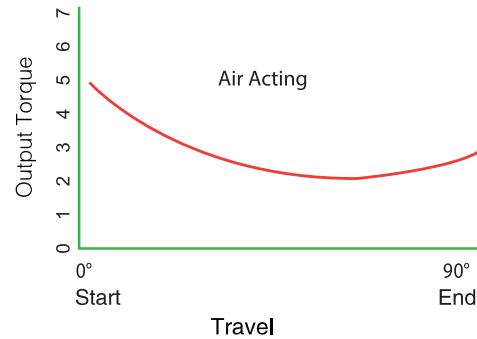
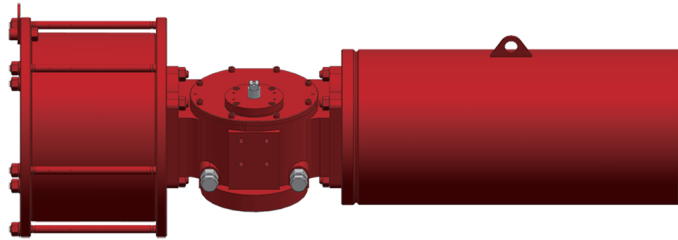

Unit:Nm

Model	3Bar						4Bar						5.5Bar						6Bar					
	Spring Acting			Air Acting			Spring Acting			Air Acting			Spring Acting			Air Acting			Spring Acting			Air Acting		
	Start	Run	End	Start	Run	End	Start	Run	End	Start	Run	End	Start	Run	End	Start	Run	End	Start	Run	End	Start	Run	End
SY30-550SR	6431	3136	4020	6812	3207	4276	8576	4181	5360	9123	4276	5702	10720	5227	7092	12909	6298	8889	12863	6272	8040	13684	6415	8553
SY35-550SR	9004	4391	5628	9479	4490	5987	12006	5854	7504	12772	5987	7983	15008	7318	9380	17503	9147	11875	18009	8781	11256	19158	8981	11974
SY35-600SR	10716	5225	6698	11400	5344	7125	14288	6967	8930	15200	7125	9500	17860	8707	11163	20824	10887	14127	21432	10450	13395	22800	10688	14250
SY35-700SR	14585	7112	9116	15517	7274	9698	19448	9483	12155	20689	9698	12931	24310	11853	15194	29275	14302	20159	29171	14224	18232	31033	14547	19396
SY40-600SR	13012	6345	8133	13843	6489	8652	17350	8460	10844	18457	8652	11536	21688	10575	13555	25309	13218	17176	26025	12690	16266	27686	12978	17304
SY40-700SR	17711	8636	11070	18842	8832	11776	23615	11515	14760	25123	11776	15702	29519	14393	18449	34427	17992	23357	35422	17272	22139	37684	17664	23553
SY40-800SR	23133	11280	14458	24610	11536	15381	30845	15039	19278	32813	15381	20508	38556	18799	24097	44968	23499	30509	46266	22559	28917	49219	23072	30762
SY48-800SR	27215	13270	17010	28953	13572	18096	36288	17693	22680	38604	18096	24127	45360	22117	28350	52901	27646	35891	54431	26540	34020	57905	27143	36191
SY48-900SR	34444	16795	21528	36644	17177	22902	45927	22393	28704	48858	22902	30536	57408	27992	35880	66933	34990	45405	68889	33590	43056	73287	34353	45804
SY48-1000SR	42524	20735	26578	45239	21206	28274	56699	27646	35437	60319	28274	37699	70874	34558	44296	82556	43197	55978	85049	41469	53156	90477	42412	56549
SY60-800SR	35380	17251	22113	37639	17643	23524	47174	23001	29484	50185	23524	31366	58967	28752	36855	71891	35346	49779	70760	34502	44226	75277	35286	47048
SY60-900SR	44778	21833	27987	47637	22330	29773	59705	29111	37315	63515	29773	39697	74631	36389	46644	92185	45487	64198	89556	43667	55973	95273	44659	59546
SY60-1000SR	55281	26955	34551	58811	27567	36757	73709	35940	46068	78414	36757	49009	92137	44925	57585	115041	57754	80489	110564	53910	69102	117621	55135	73513
SY60-1100SR	66891	32615	41807	71161	33357	44476	89188	43487	55743	94881	44476	59301	111485	54359	69678				133782	65231	83614	142321	66713	88951

*maximum air supply pressure is 116 psi

Output Torque

Double Acting Output Torque of SY Series Actuator (DA)

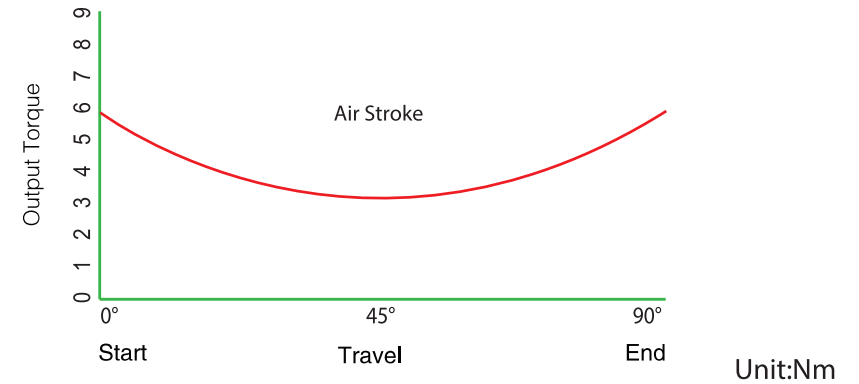
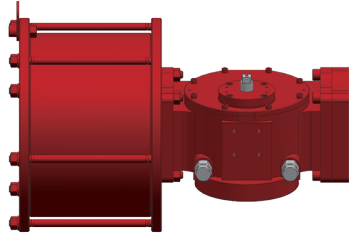

Model	3Bar			4Bar			5.5Bar			6Bar		
	Start	Running	End	Start	Running	End	Start	Running	End	Start	Running	End
SY10-150DA	306	173	306	405	208	405	560	283	560	611	310	611
SY10-170DA	398	245	398	523	310	523	719	364	719	- *	- *	- *
SY12-170DA	491	285	491	654	387	654	902	520	902	987	564	987
SY12-200DA	689	391	689	905	452	905	1244	690	1244	1357	815	1357
SY14-200DA	839	509	839	1108	679	1108	1528	933	1528	1670	1018	1670
SY14-250DA	1295	795	1295	1736	1060	1736	2389	1458	2389	- *	- *	- *
SY14-300DA	1862	1145	1862	- *	- *	- *	- *	- *	- *	- *	- *	- *
SY16-250DA	1625	994	1625	2164	1325	2164	3011	1823	3011	3310	1988	3310
SY16-300DA	2335	1431	2335	3121	1909	3121	4278	2625	4278	- *	- *	- *
SY16-350DA	3181	1948	3181	4239	2589	4239	- *	- *	- *	- *	- *	- *
SY25-350DA	3924	2338	3924	5237	3117	5237	7204	4287	7204	7861	4676	7861
SY25-400DA	4985	3054	4985	6642	4072	6642	9144	5598	9144	- *	- *	- *
SY25-450DA	6308	3865	6308	8413	5153	8413	- *	- *	- *	- *	- *	- *
SY30-450DA	7720	4294	7720	10291	5726	10291	14143	7873	14143	15431	8588	15431
SY30-500DA	9514	5301	9514	12694	7069	12694	17454	9720	17454	- *	- *	- *

- * The torque is more than the maximum flange torque value stipulated by ISO5211.

*maximum air supply pressure is 116 psi

Output Torque

Double Acting Output Torque of SY Series Actuator (DA)

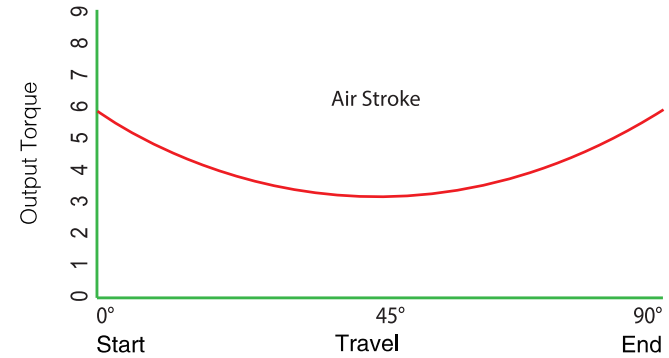
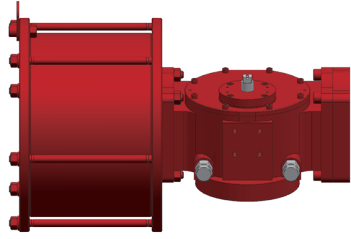

Unit:Nm

Model	3Bar			4Bar			5.5Bar			6Bar		
	Start	Running	End	Start	Running	End	Start	Running	End	Start	Running	End
SY30-550DA	11520	6415	11520	15363	9105	15363	- *	- *	- *	- *	- *	- *
SY35-550DA	14670	8981	14670	19551	11974	19551	26883	16465	26883	29324	17961	29324
SY35-600DA	17454	10688	17454	23263	14250	23263	31987	19594	31987	34896	21375	34896
SY35-700DA	23751	14547	23751	31678	19396	31678	- *	- *	- *	- *	- *	- *
SY40-600DA	- **	- **	- **	- *	- *	- *	38864	23793	38894	42377	25956	42377
SY40-700DA	- **	- **	- **	38440	23553	38440	52876	32385	52876	57681	35329	57681
SY40-800DA	37682	29584	37682	50318	39852	50318	69065	42298	69065	- *	- *	- *
SY48-800DA	- **	- **	- **	- *	- *	- *	81251	49763	81251	88640	54287	88640
SY48-900DA	- **	- **	- **	74762	45804	74762	102813	62982	102813	112140	68707	112140
SY48-1000DA	69285	42412	69285	92351	56549	92351	126852	77755	126852	- *	- *	- *
SY60-800DA	- **	- **	- **	- *	- *	- *	- *	- *	- *	119621	70508	119621
SY60-900DA	- **	- **	- **	100965	59546	100965	138829	81876	138829	151456	89319	151456
SY60-1000DA	93476	55135	93476	124639	75654	124639	172626	102679	172626	189450	113466	189450
SY60-1100DA	113082	66713	113082	150789	88951	150789	207314	122308	207314	226162	133427	226162

- ** The torque is too small for operation.

- * The torque is more than the maximum flange torque value stipulated by ISO5211.

*maximum air supply pressure is 116 psi

Output Torque

Double Acting Output Torque of SY Series Actuator (DA)

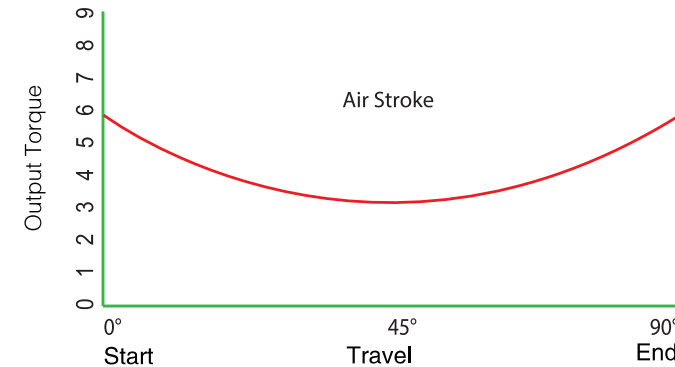
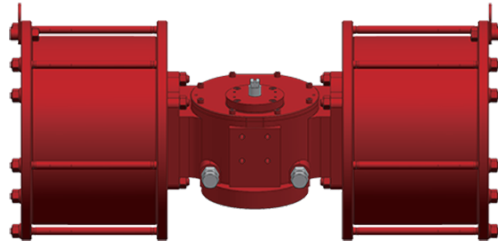

Unit:Nm

Model	3Bar			4Bar			5.5Bar			6Bar		
	Start	Running	End	Start	Running	End	Start	Running	End	Start	Running	End
SY16-141-DA	1055	561	1055	1407	748	1407	1934	1029	1934	2110	1122	2110
SY16-161-DA	1378	733	1378	1837	977	1837	2526	1344	2526	2756	1466	2756
SY16-201-DA	2153	1145	2153	2870	1527	2870	3947	2100	3947	4306	2290	4306
SY25-201-DA	2583	1374	2583	3444	1832	3444	4767	2519	4767	5167	2748	5167
SY25-251-DA	4037	2147	4037	5382	2863	5382	7401	3936	7401	8073	4294	8073
SY25-301-DA	5813	3092	5813	7750	4122	7750	- *	- *	- *	- *	- *	- *
SY30-301-DA	6458	3435	6458	8611	4580	8611	11841	6299	11841	12917	6871	12917
SY30-351-DA	8791	4676	8791	11721	6234	11721	16116	8573	16116	17581	9352	17581
SY30-401-DA	11482	6107	11482	15309	8143	15309	- *	- *	- *	- *	- *	- *
SY35-401-DA	16074	8550	16074	21432	11400	21432	29470	15675	29470	32149	17100	32149
SY35-451-DA	20344	10821	20344	27125	14428	27125	- *	- *	- *	- *	- *	- *

- * The torque is more than the maximum flange torque value stipulated by ISO5211.

*maximum air supply pressure is 116 psi

Output Torque

Double Acting Output Torque of SY Series Actuator (DA)

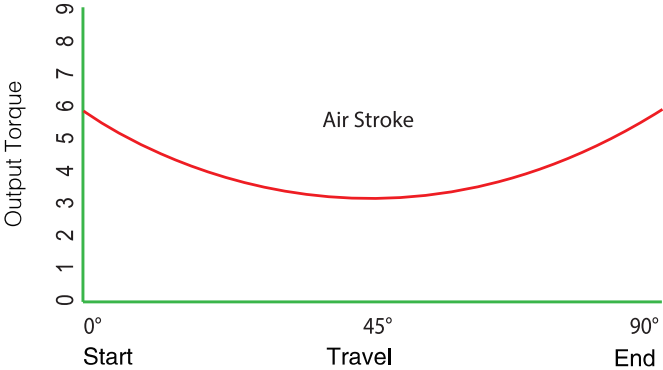
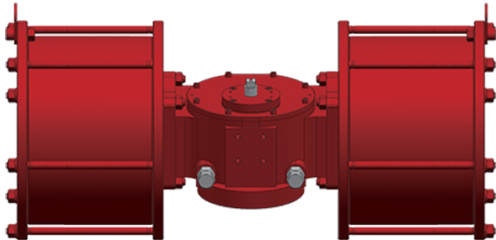

Unit:Nm

Model	3Bar			4Bar			5.5Bar			6Bar		
	Start	Running	End	Start	Running	End	Start	Running	End	Start	Running	End
SY35-501-DA	25116	13360	25116	33488	17813	33488	46046	24493	46046	50232	26719	50232
SY40-501-DA	30498	16222	30498	40664	21630	40664	55913	29741	55913	60996	32445	60996
SY40-551-DA	36903	19629	36903	49204	26172	49204	67656	35987	67656	- *	- *	- *
SY40-601-DA	43917	23360	43917	58556	31147	58556	- *	- *	- *	- *	- *	- *
SY48-601-DA	51667	27483	51667	68890	36644	68890	94724	50385	94724	103335	54965	103335
SY48-651-DA	60637	32254	60637	80850	43005	80850	111169	59133	111169	121275	64508	121275
SY48-701-DA	70325	37407	70325	93767	49876	93767	128929	68580	128929	- *	- *	- *
SY48-801-DA	91853	48858	91853	122471	65144	122471	- *	- *	- *	- *	- *	- *
SY60-801-DA	119409	63515	119409	159212	84687	159212	218917	116445	218917	238818	127031	238818
SY60-901-DA	151127	80387	151127	201503	107182	201503	277067	147376	277067	- *	- *	- *
SY60-1001-DA	186577	99243	186577	248769	132324	248769	- *	- *	- *	- *	- *	- *

- * The torque is more than the maximum flange torque value stipulated by ISO5211.

*maximum air supply pressure is 116 psi

Dimensions

Dimension of SY Series Spring Return Actuator(SR)

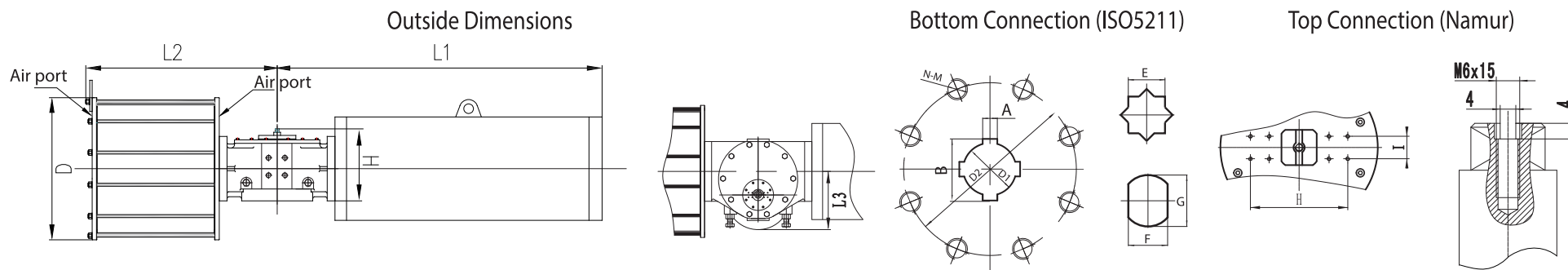

Unit : mm

Model	Outside Dimensions					Female Drive Connection						Flange Connection			Top Connection (Napur)		Air Port
						Keyed (FK)			Double Square (FS)		Double D (FD)						
	D	L1	L2	L3	H	A	B	D1	E	F	G	D2	N-M	ISO5211	I	H	
SY10-150SR	210	445	240	80	165	8	34.6	28	22	22	28.2	102	4-M10	F10	30	80	3/8"NPT / BSPP
SY10-170SR	230	445	240	80	165	8	34.6	28	22	22	28.2	102	4-M10	F10	30	80	3/8"NPT / BSPP
SY12-170SR	230	620	290	90	170	10	42.6	36	27	27	36.2	125	4-M12	F12	30	80	3/8"NPT / BSPP
SY12-200SR	260	620	290	90	170	10	42.6	36	27	27	36.2	125	4-M12	F12	30	80	3/8"NPT / BSPP
SY14-200SR	260	680	370	150	200	12	48.6	42	36	36	48.2	140	4-M16	F14	30	80	3/8"NPT / BSPP
SY14-250SR	310	680	370	150	200	12	48.6	42	36	36	48.2	140	4-M16	F14	30	80	1/2"NPT / BSPP
SY14-300SR	370	680	370	150	200	12	48.6	42	36	36	48.2	140	4-M16	F14	30	80	1/2"NPT / BSPP
SY16-250SR	310	910	470	180	210	18	68.8	60	46	46	60.2	165	4-M20	F16	30	80	1/2"NPT / BSPP
SY16-300SR	370	910	470	180	210	18	68.8	60	46	46	60.2	165	4-M20	F16	30	80	1/2"NPT / BSPP
SY16-350SR	430	970	470	180	210	18	68.8	60	46	46	60.2	165	4-M20	F16	30	80	1/2"NPT / BSPP
SY16-400SR	480	970	470	180	210	18	68.8	60	46	46	60.2	165	4-M20	F16	30	80	3/4"NPT / BSPP
SY25-350SR	430	1040	540	240	230	20	81.8	72	55	55	72.2	254	8-M16	F25	30	80	1/2"NPT / BSPP
SY25-400SR	480	1040	540	240	230	20	81.8	72	55	55	72.2	254	8-M16	F25	30	80	3/4"NPT / BSPP

Dimension of SY Series Spring Return Actuator(SR)

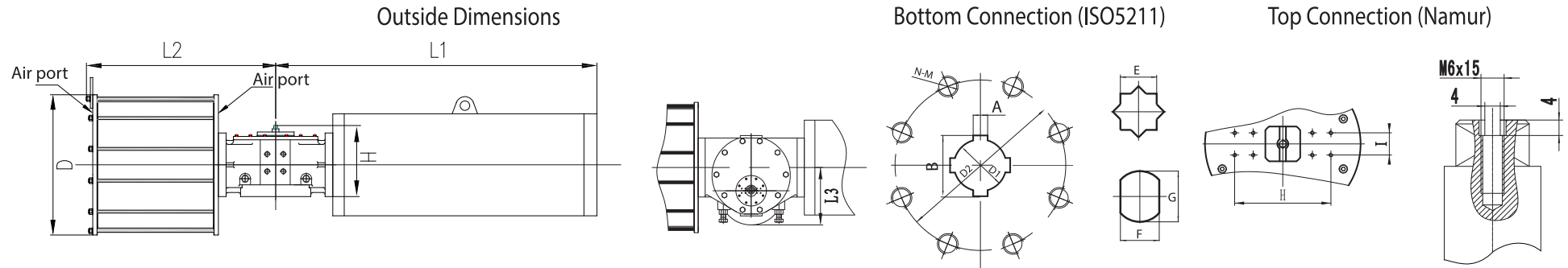

Unit : mm

Model	Outside Dimensions					Female Drive Connection						Flange Connection			Top Connection (Namur)		Air Port
						Keyed (FK)			Double Square (FS)		Double D (FD)						
	D	L1	L2	L3	H	A	B	D1	E	F	G	D2	N-M	ISO5211	I	H	
SY25-450SR	530	1100	540	240	230	20	81.8	72	55	55	72.2	254	8-M16	F25	30	80	3/4"NPT / BSPP
SY30-450SR	530	1145	620	275	275	22	90.8	80	75	75	98.2	298	8-M20	F30	30	130(80)	3/4"NPT / BSPP
SY30-500SR	580	1145	620	275	275	22	90.8	80	75	75	98.2	298	8-M20	F30	30	130(80)	3/4"NPT / BSPP
SY30-550SR	630	1205	620	275	275	22	90.8	80	75	75	98.2	298	8-M20	F30	30	130(80)	3/4"NPT / BSPP
SY35-550SR	630	1205	810	350	275	28	112.8	100	-	-	-	356	8-M30	F35	30	130(80)	3/4"NPT / BSPP
SY35-600SR	690	1205	810	350	275	28	112.8	100	-	-	-	356	8-M30	F35	30	130(80)	1"NPT / BSPP
SY35-700SR	790	1205	810	350	275	28	112.8	100	-	-	-	356	8-M30	F35	30	130(80)	1"NPT / BSPP
SY35-800SR	900	1355	810	350	275	28	112.8	100	-	-	-	356	8-M30	F35	30	130(80)	1 1/2"NPT / BSPP
SY40-600SR	690	1780	960	410	350	40	178.8	160	-	-	-	406	8-M36	F40	30	130(80)	1"NPT / BSPP
SY40-700SR	790	1780	960	410	350	40	178.8	160	-	-	-	406	8-M36	F40	30	130(80)	1"NPT / BSPP
SY40-800SR	900	1780	960	410	350	40	178.8	160	-	-	-	406	8-M36	F40	30	130(80)	1 1/2"NPT / BSPP
SY40-900SR	1020	1810	960	410	350	40	178.8	160	-	-	-	406	8-M36	F40	30	130(80)	2"NPT / BSPP

Dimensions

Dimension of SY Series Spring Return Actuator(SR)

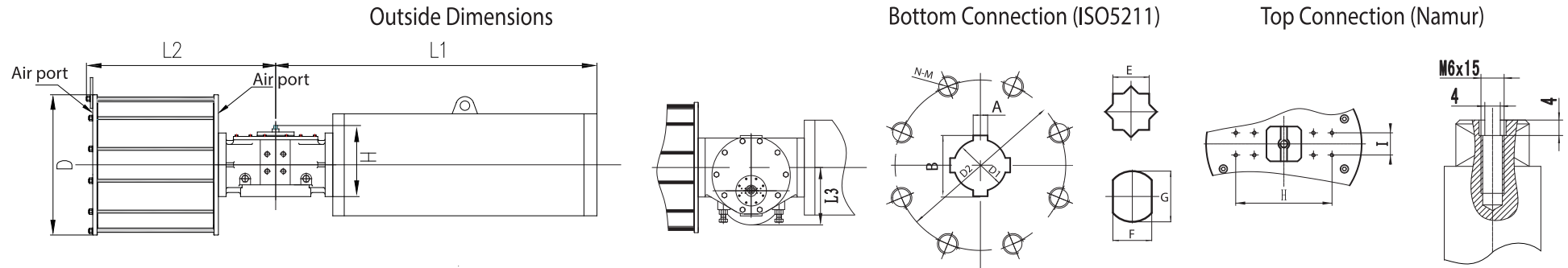

Unit : mm

Model	Outside Dimensions					Female Drive Connection						Flange Connection			Top Connection (Napur)		Air Port
						Keyed (FK)			Double Square (FS)	Double D (FD)							
	D	L1	L2	L3	H	A	B	D1	E	F	G	D2	N-M	ISO5211	I	H	
SY40-1000SR	1130	1810	960	410	350	40	178.8	160	-	-	-	406	8-M36	F40	30	130(80)	2"NPT / BSPP
SY48-800SR	900	2260	1120	480	420	45	200.8	180	-	-	-	483	12-M36	F48	30	130(80)	1 1/2"NPT / BSPP
SY48-900SR	1020	2260	1120	480	420	45	200.8	180	-	-	-	483	12-M36	F48	30	130(80)	2"NPT / BSPP
SY48-1000SR	1130	2260	1120	480	420	45	200.8	180	-	-	-	483	12-M36	F48	30	130(80)	2"NPT / BSPP
SY48-1100SR	1250	2450	1120	480	420	45	200.8	180	-	-	-	483	12-M36	F48	30	130(80)	2"NPT / BSPP
SY48-1200SR	1370	2450	1120	480	420	45	200.8	180	-	-	-	483	12-M36	F48	30	130(80)	2"NPT / BSPP
SY60-800SR	900	2735	1365	603	500	50	242.8	220	-	-	-	603	20-M36	F60	30	130(80)	1 1/2"NPT / BSPP
SY60-900SR	1020	2735	1365	603	500	50	242.8	220	-	-	-	603	20-M36	F60	30	130(80)	2"NPT / BSPP
SY60-1000SR	1130	2735	1365	603	500	50	242.8	220	-	-	-	603	20-M36	F60	30	130(80)	2"NPT / BSPP
SY60-1100SR	1250	2735	1365	603	500	50	242.8	220	-	-	-	603	20-M36	F60	30	130(80)	2"NPT / BSPP
SY60-1200SR	1370	3260	1365	603	500	50	242.8	220	-	-	-	603	20-M36	F60	30	130(80)	2"NPT / BSPP
SY60-1300SR	1480	3490	1365	603	500	50	242.8	220	-	-	-	603	20-M36	F60	30	130(80)	2"NPT / BSPP

Dimensions

Dobule Acting Dimension of SY Series Actuator (DA)

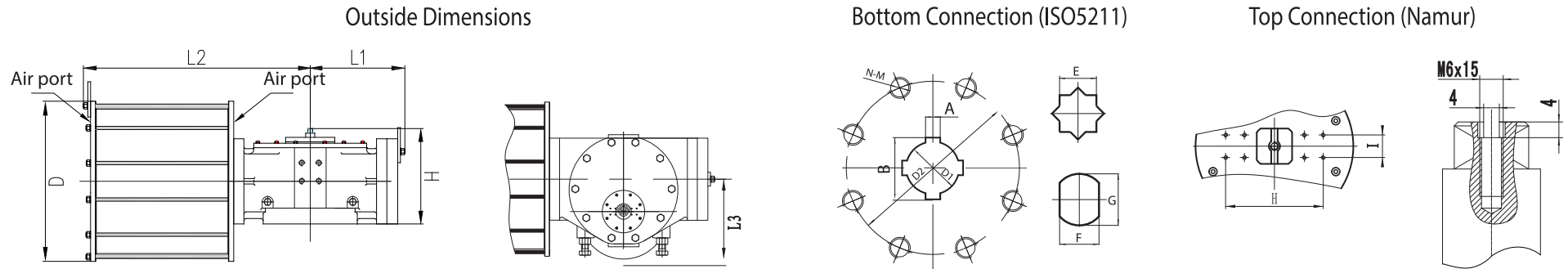

Unit : mm

Model	Outside Dimensions					Female Drive Connection						Flange Connection			Top Connection (Napur)		Air Port
						Keyed (FK)			Double Square (FS)	Double D (FD)							
	D	L1	L2	L3	H	A	B	D1	E	F	G	D2	N-M	ISO5211	I	H	
SY14-200DA	270	170	370	170	200	12	48.6	42	36	36	48.2	140	4-M16	F14	30	80	3/8"NPT /BSPP
SY14-250DA	320	170	370	170	200	12	48.6	42	36	36	48.2	140	4-M16	F14	30	80	1/2"NPT /BSPP
SY14-300DA	380	170	370	170	200	12	48.6	42	36	36	48.2	140	4-M16	F14	30	80	1/2"NPT /BSPP
SY16-250DA	320	190	440	180	210	18	68.8	60	46	46	60.2	165	4-M20	F16	30	80	1/2"NPT /BSPP
SY16-300DA	380	190	440	180	210	18	68.8	60	46	46	60.2	165	4-M20	F16	30	80	1/2"NPT /BSPP
SY16-350DA	430	190	440	180	210	18	68.8	60	46	46	60.2	165	4-M20	F16	30	80	1/2"NPT /BSPP
SY25-350DA	430	230	510	210	230	20	81.8	72	55	55	72.2	254	8-M16	F25	30	80	1/2"NPT /BSPP
SY25-400DA	480	230	510	210	230	20	81.8	72	55	55	72.2	254	8-M16	F25	30	80	3/4"NPT /BSPP
SY25-450DA	530	230	510	210	230	20	81.8	72	55	55	72.2	254	8-M16	F25	30	80	3/4"NPT /BSPP
SY30-450DA	530	280	580	250	275	22	90.8	80	75	75	98.2	298	8-M20	F30	30	130(80)	3/4"NPT /BSPP
SY30-500DA	580	280	580	250	275	22	90.8	80	75	75	98.2	298	8-M20	F30	30	130(80)	3/4"NPT /BSPP
SY30-550DA	640	280	580	250	275	22	90.8	80	75	75	98.2	298	8-M20	F30	30	130(80)	3/4"NPT /BSPP

Dimensions

Dobule Acting Dimension of SY Series Actuator (DA)

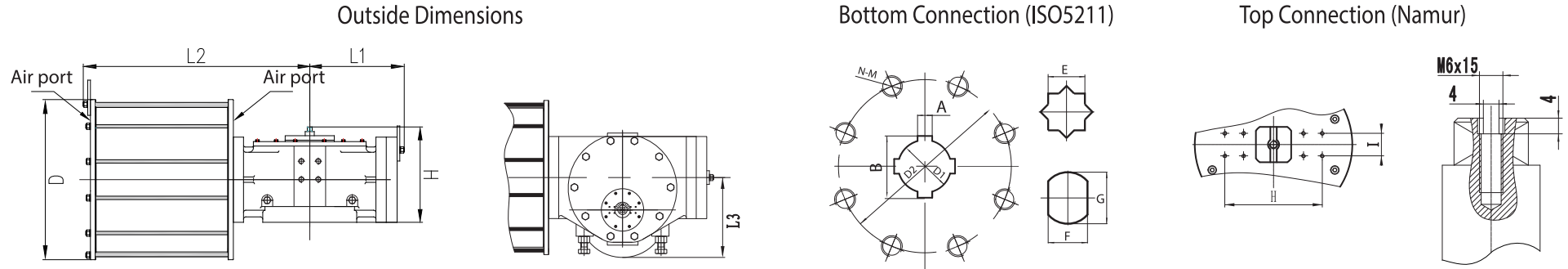

Unit : mm

Model	Outside Dimensions					Female Drive Connection						Flange Connection			Top Connection (Namura)		Air Port
						Keyed (FK)			Double Square (FS)		Double D (FD)						
	D	L1	L2	L3	H	A	B	D1	E	F	G	D2	N-M	ISO5211	I	H	
SY35-550DA	640	330	830	350	310	28	112.8	100	-	-	-	356	8-M30	F35	30	130(80)	3/4"NPT / BSPP
SY35-600DA	690	330	830	350	310	28	112.8	100	-	-	-	356	8-M30	F35	30	130(80)	1"NPT / BSPP
SY35-700DA	800	330	830	350	310	28	112.8	100	-	-	-	356	8-M30	F35	30	130(80)	1"NPT / BSPP
SY40-600DA	690	380	970	400	350	40	178.8	160	-	-	-	406	8-M36	F40	30	130(80)	1"NPT / BSPP
SY40-700DA	800	380	970	400	350	40	178.8	160	-	-	-	406	8-M36	F40	30	130(80)	1"NPT / BSPP
SY40-800DA	900	380	970	400	350	40	178.8	160	-	-	-	406	8-M36	F40	30	130(80)	1 1/2"NPT / BSPP
SY48-800DA	900	410	1120	450	420	45	200.8	180	-	-	-	483	12-M36	F48	30	130(80)	1 1/2"NPT / BSPP
SY48-900DA	1000	410	1120	450	420	45	200.8	180	-	-	-	483	12-M36	F48	30	130(80)	2"NPT / BSPP
SY48-1000DA	1100	410	1120	450	420	45	200.8	180	-	-	-	483	12-M36	F48	30	130(80)	2"NPT / BSPP
SY60-900DA	1000	440	1260	520	500	50	242.8	220	-	-	-	603	20-M36	F60	30	130(80)	2"NPT / BSPP
SY60-1000DA	1100	440	1260	520	500	50	242.8	220	-	-	-	603	20-M36	F60	30	130(80)	2"NPT / BSPP
SY60-1100DA	1200	440	1260	520	500	50	242.8	220	-	-	-	603	20-M36	F60	30	130(80)	2"NPT / BSPP

Dimensions

Dobule Acting Dimension of SY Series Actuator (DA)

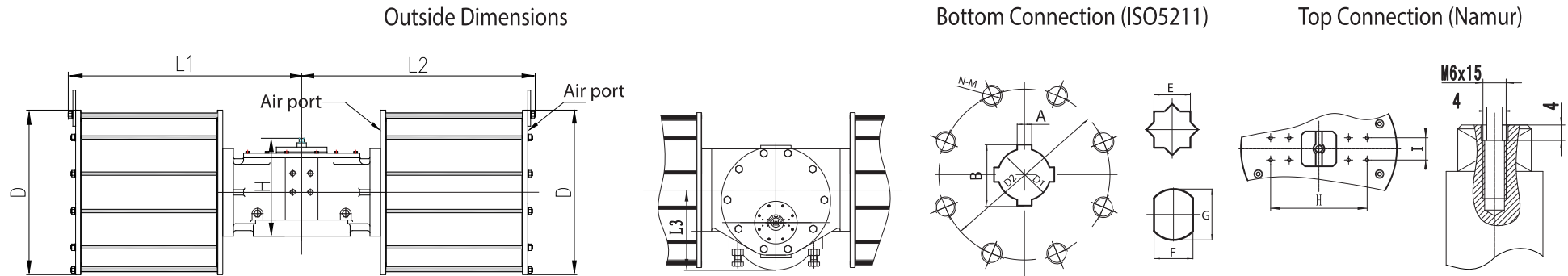

Unit : mm

Model	Outside Dimensions					Female Drive Connection						Flange Connection			Top Connection (Napur)		Air Port
						Keyed (FK)			Double Square (FS)	Double D (FD)							
	D	L1	L2	L3	H	A	B	D1	E	F	G	D2	N-M	ISO5211	I	H	
SY16-141-DA	200	440	440	180	210	18	68.8	60	46	46	60.2	165	4-M20	F16	30	80	3/8"NPT / BSPP
SY16-161-DA	220	440	440	180	210	18	68.8	60	46	46	60.2	165	4-M20	F16	30	80	3/8"NPT / BSPP
SY16-201-DA	270	440	440	180	210	18	68.8	60	46	46	60.2	165	4-M20	F16	30	80	3/8"NPT / BSPP
SY25-201-DA	270	510	510	210	230	20	81.8	72	55	55	72.2	254	8-M16	F25	30	80	3/8"NPT / BSPP
SY25-251-DA	320	510	510	210	230	20	81.8	72	55	55	72.2	254	8-M16	F25	30	80	1/2"NPT / BSPP
SY25-301-DA	380	510	510	210	230	20	81.8	72	55	55	72.2	254	8-M16	F25	30	80	1/2"NPT / BSPP
SY30-301-DA	380	580	580	250	275	22	90.8	80	75	75	98.2	298	8-M20	F30	30	130(80)	1/2"NPT / BSPP
SY30-351-DA	430	580	580	250	275	22	90.8	80	75	75	98.2	298	8-M20	F30	30	130(80)	1/2"NPT / BSPP
SY30-401-DA	480	580	580	250	275	22	90.8	80	75	75	98.2	298	8-M20	F30	30	130(80)	3/4"NPT / BSPP
SY35-401-DA	480	830	830	350	310	28	112.8	100	-	-	-	356	8-M30	F35	30	130(80)	3/4"NPT / BSPP
SY35-451-DA	530	830	830	350	310	28	112.8	100	-	-	-	356	8-M30	F35	30	130(80)	3/4"NPT / BSPP

Dimensions

Dobule Acting Dimension of SY Series Actuator (DA)

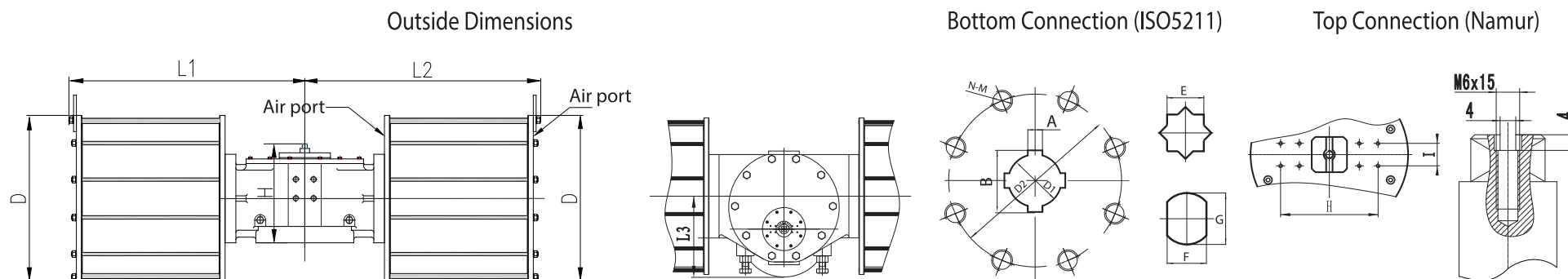

Unit : mm

Model	Outside Dimensions					Female Drive Connection						Flange Connection			Top Connection (Napur)		Air Port
						Keyed (FK)			Double Square (FS)	Double D (FD)							
	D	L1	L2	L3	H	A	B	D1	E	F	G	D2	N-M	ISO5211	I	H	
SY35-501-DA	580	830	830	350	310	28	112.8	100	-	-	-	356	8-M30	F35	30	130(80)	3/4"NPT / BSPP
SY40-501-DA	580	970	970	400	350	40	178.8	160	-	-	-	406	8-M36	F40	30	130(80)	3/4"NPT / BSPP
SY40-551-DA	630	970	970	400	350	40	178.8	160	-	-	-	406	8-M36	F40	30	130(80)	3/4"NPT / BSPP
SY40-601-DA	690	970	970	400	350	40	178.8	160	-	-	-	406	8-M36	F40	30	130(80)	1"NPT / BSPP
SY48-601-DA	690	1120	1120	450	420	45	200.8	180	-	-	-	483	12-M36	F48	30	130(80)	1"NPT / BSPP
SY48-651-DA	740	1120	1120	450	420	45	200.8	180	-	-	-	483	12-M36	F48	30	130(80)	1"NPT / BSPP
SY48-701-DA	800	1120	1120	450	420	45	200.8	180	-	-	-	483	12-M36	F48	30	130(80)	1"NPT / BSPP
SY48-801-DA	900	1120	1120	450	420	45	200.8	180	-	-	-	483	12-M36	F48	30	130(80)	1 1/2"NPT / BSPP
SY60-801-DA	900	1260	1260	520	500	50	242.8	220	-	-	-	603	20-M36	F60	30	130(80)	1 1/2"NPT / BSPP
SY60-901-DA	1000	1260	1260	520	500	50	242.8	220	-	-	-	603	20-M36	F60	30	130(80)	2"NPT / BSPP
SY60-1001-DA	1100	1260	1260	520	500	50	242.8	220	-	-	-	603	20-M36	F60	30	130(80)	2"NPT / BSPP

Air Consumption

SY Series Air volume opening & closing

Model	Volume Opening (L)	Model	Volume Opening (L)
SY10-150DA	1.68	SY30-550DA	56.52
SY10-170DA	2.17	SY35-550DA	78.89
SY12-170DA	2.68	SY35-600DA	93.72
SY12-200DA	3.69	SY35-700DA	110.16
SY14-200DA	4.42	SY40-600DA	113.87
SY14-250DA	6.97	SY40-700DA	155.40
SY14-300DA	10.03	SY40-800DA	203.13
SY16-250DA	8.70	SY48-800DA	238.56
SY16-300DA	12.55	SY48-900DA	302.35
SY16-350DA	17.14	SY48-1000DA	373.39
SY25-350DA	20.56	SY60-800DA	309.93
SY25-400DA	26.86	SY60-900DA	392.80
SY25-450DA	34.07	SY60-1000DA	485.10
SY30-450DA	37.85	SY60-1100DA	587.47
SY30-500DA	46.63		

Open Position of SY Actuators

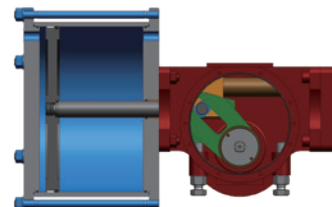

Model	Volume Closing (L)	Model	Volume Closing (L)
SY10-150DA	1.71	SY30-550DA	56.99
SY10-170DA	2.20	SY35-550DA	79.55
SY12-170DA	2.72	SY35-600DA	94.67
SY12-200DA	3.77	SY35-700DA	111.11
SY14-200DA	4.52	SY40-600DA	115.02
SY14-250DA	7.07	SY40-700DA	156.55
SY14-300DA	10.17	SY40-800DA	204.48
SY16-250DA	8.83	SY48-800DA	240.15
SY16-300DA	12.72	SY48-900DA	303.94
SY16-350DA	17.31	SY48-1000DA	375.23
SY25-350DA	20.77	SY60-800DA	311.99
SY25-400DA	27.13	SY60-900DA	394.86
SY25-450DA	34.34	SY60-1000DA	487.49
SY30-450DA	38.15	SY60-1100DA	589.86
SY30-500DA	47.10		

Close Position of SY Actuators

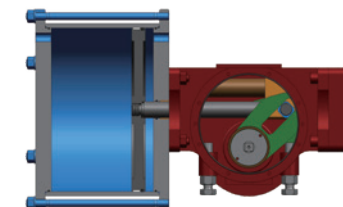

Air consumption rest with Air Supply. Air volume and Action cycle times, expressions:

$$L/Min = \text{Air volume}(\text{Air volume Opening} + \text{Air volume closing}) \times [(\text{Air Supply}(Kpa) + 101.3) \div 101.3] \times \text{Action cycle times} (/min)$$

ASY Additional Devices

SY series scotch yoke pneumatic actuators are available to arm with additional devices (manual overrides and travel stopers) to meet some special requirement, such as the assembly debugging in test run, emergency shut down in power failure and safety travel stop in the operation of quick stroke within 5s).

Hand wheel Override (HW). As for SY10-XXSR to ASY16-XXSR actuators, the hand wheel manual overrider is armed on the side of the spring cartridge. Note that this kind of hand wheel manual override also is available for SY series double acting actuators.

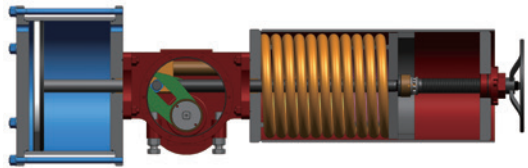

Open position operated by hand wheel.

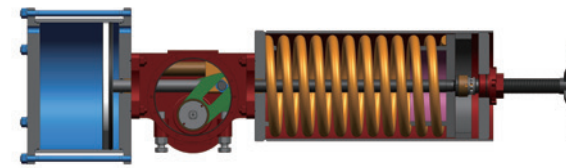

Closed position operated by hand wheel.

Hydraulic Override (HY). As for SY25 to ASY60 series actuators, the hydraulic overrides are available both for double acting and spring return.

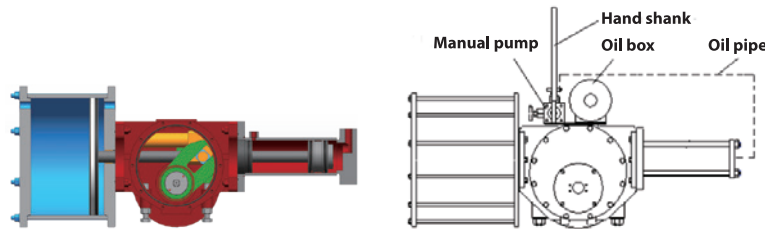

SY double acting actuator with hydraulic override.

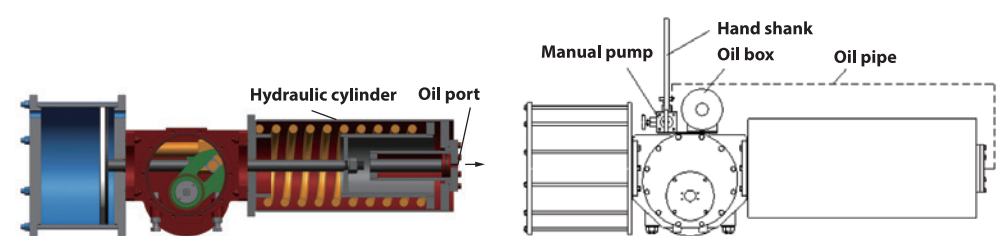

SY spring return actuator hydraulic override

Extended mechanical travel stop (EX). As a standard configuration, SY yoke mechanism fitted with mechanical end stops (open or closed positions) inside of centre body to ensure adjustable range of $\pm 6^\circ$. For quick stroke operation within 5s, SY offers an extended mechanical travel stops (EX) in each end of the actuator to ensure travel stop safely and adjustable range of $\pm 6^\circ$ at stop positions reliably.

Double acting SY actuators are built with EX stops.

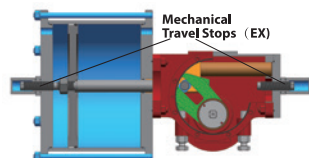

Spring return SY actuators are built with EX stops.

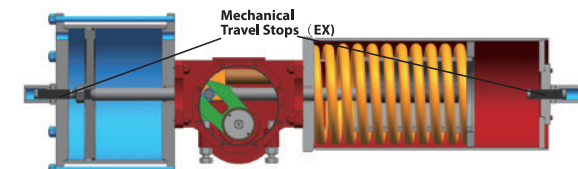

Spring Return Actuator configuration

For the CVS SY spring return actuator, fail-close or fail-open modules are dependant on the configuration. Because of sharing modular construction, these modules can be required when ordering or reconfiguration by customer accordingly.

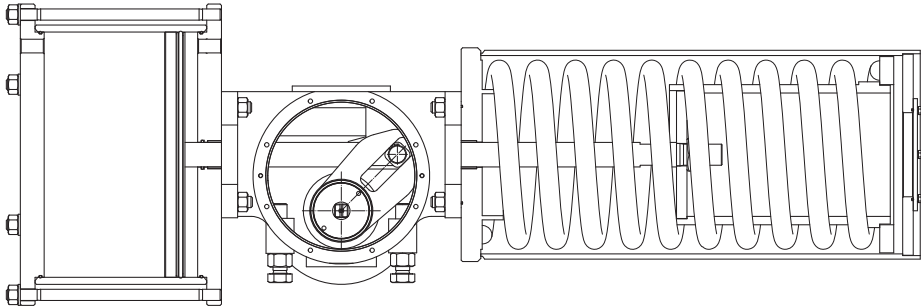
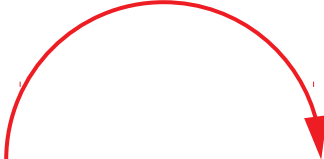
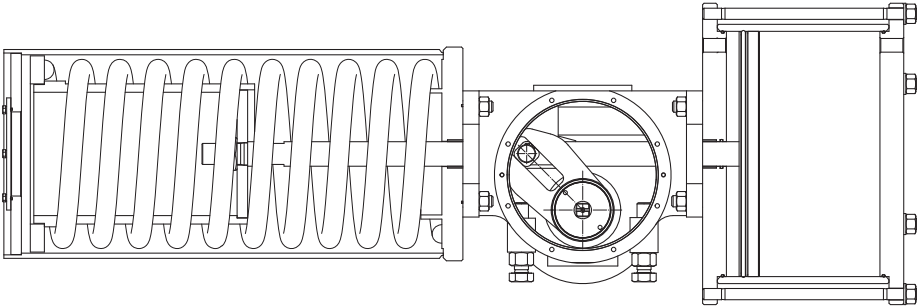
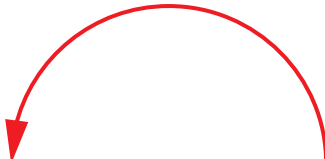
Spring Return Actuator configuration	Fail Direction	
 <p data-bbox="293 826 987 914">Cylinder Module on left side Spring cartridge Module is in right side</p>	<p data-bbox="1252 651 1570 738">CW Fail to Closed (FC)</p>	
 <p data-bbox="338 1337 1003 1425">Cylinder Module on right side Spring cartridge Module is in left side</p>	<p data-bbox="1263 1137 1559 1225">CCW Fail to Open (FO)</p>	

Accessories and Application

CVS Controls is available to supply accessories, such as solenoid valves, limit switch boxes, and valve positioners, to be assembly with SY scotch yoke actuators based on Namur and ISO5211 standards. These accessories can be mounted on a panel or in a cabinet or mounted on the actuator directly.



CVS

CONTROLS

HEAD OFFICE

1107 8A Street
Nisku, Alberta
T9E 7R3
Canada
P: 780.437.3055

CALGARY OFFICE

3516 114 Avenue SE
Calgary, Alberta
T2Z 3V6
Canada
P: 403.250.1416
F: 403.291.9487

Website: cvs-controls.com

EMAIL: info@cvs-controls.com