

# Instruction Manual

## CVS Series E 8-Inch Globe Valves

Design “ED” and “ET”

### Introduction

Contained in this manual are installation instructions, maintenance procedures and parts information for the 8-inch designs CVS Series E Valve Body. Refer to the appropriate manuals for the accompanying actuator, positioner and additional accessories.

Trained or experienced personnel should carry out operation and installation of all pressure equipment. If you have any questions regarding the equipment, contact your CVS Controls representative.

### Application And Features

The CVS Series E is a single port, globe-style body with composition or metal seats and a balanced push-down-to-close valve action plug.

There are two styles of valve available, providing excellent pressure and flow control on steam gasses and various liquid applications:

1. **Design ED** is intended for general control applications over a wide variety of temperatures and pressure drops. This design has an upper piston ring seal and metal-to-metal seating.
2. **Design ET** is intended for applications requiring low leakage rates with composition seating (TFE) for tight shutoff requirements or metal-to-metal seating for higher temperature capabilities. The valve plug has a two-piece upper seal.



**Figure 1: CVS Series E 8-Inch Control Valve with CVS 667 Diaphragm Actuator**

For standard cages the flow direction is flow-down. The following flow characteristics are available: linear, quick opening and equal percent.

The end connections are ASME Class 150, 300 and 600 Raised Face, or Ring Type Joint flanges as per ASME B16.34-latest edition.

Available in LCC, WCB, WCC, WC9, C5, Monel, and CF8M SST body materials. Other materials may be available upon request.

Sour Service Capability

Optional NACE MRO175/ISO15156-2009

The approximate shipping weight is 900 lbs (408 kg).

**Head Office**  
3900 – 101 Street  
Edmonton, Alberta, Canada T6E 0A5  
Office: (780) 437-3055  
Fax: (780) 436-5461

**CVS**  
CONTROLS

**Calgary Sales Office**  
3516 114 Avenue SE  
Calgary, Alberta, Canada T2Z 3V6  
Office: (403) 250-1416  
Fax: (403) 291-9487

Website: [www.cvs-controls.com](http://www.cvs-controls.com) E-Mail: [info@cvs-controls.com](mailto:info@cvs-controls.com)

## Installation

The CVS 8" Series E valve should not be installed in systems that exceed the ANSI specified temperature and pressure ratings.

Inspect the valves for shipping damage and foreign debris when uncrating.

1. Ensure the pipe is free of welding slag, chips, and other debris by cleaning out the lines before installation.
2. Install approved gaskets between the valve body and the pipeline flanges.
3. CVS Controls recommends a standard three-valve maintenance bypass be installed. This allows isolation of the valve body without shutting down the pipeline system.
4. Install the valve so that the flow direction arrow on the body coincides with the actual process flow through the valve.
5. Although the valve can be installed in any position, the typical installation has the actuator vertical above the valve body. Support for the actuator will be necessary if there is vibration in the line or if the valve body is positioned 45 degrees or more below vertical.

## Maintenance

Before beginning any maintenance, it is important to isolate the control valve and release all pressure contained in the valve body and the actuator. Disconnect any operating lines providing air pressure, control signals or electrical power to the actuator.

**Note: Caution must be used in the disassembly. The seating surfaces and surface finish of the cage; seat ring, stem, and plug are critical for proper sealing. Nicks and scratches will affect the ability to seal the valve in the future.**

### Disassembly

1. Disconnect and remove the actuator from the body.
2. Remove the nuts or cap screws from the bonnet flange.
3. Thread one of the actuator stem locknuts onto the stem and continue threading it down to the bottom of the thread run out.

4. Remove the bonnet by lifting it straight up with a hoist. Attach the hoist by either a double cable hoisting sling under the bonnet or by the lifting rings attached to the packing flange stud bolts or on the 5" yoke bosses to two yoke stud bolts 180° apart.
5. Caution must be used when lifting the bonnet to ensure that it clears the body and stud bolts completely. Any damage to the seating surface will compromise future sealing ability.
6. To prevent damage to the seating surface, place the bonnet-valve plug assembly on a wooden or cushioned surface.

### Replacing the Plug Stem or Load Ring

1. Unscrew the locknuts from the stem.
2. Loosen the packing flange nuts.
3. Lean the bonnet over.
4. Draw the plug and stem out of the bonnet.
5. If valve plug is damaged it will be necessary to replace both the valve plug and stem. If the stem is damaged, a new valve stem can be inserted in the original valve plug.

### Replacing the Stem

1. Remove the old groove pin
2. Remove the old stem, and replace with new stem.
3. Tighten the new stem until the thread bottoms out against the plug.
4. Drill through the stem using the hole in the valve plug as guide. Remove any chips or burrs and drive in a new groove pin to lock the assembly. Refer to Table 1 for groove pin drill sizes.

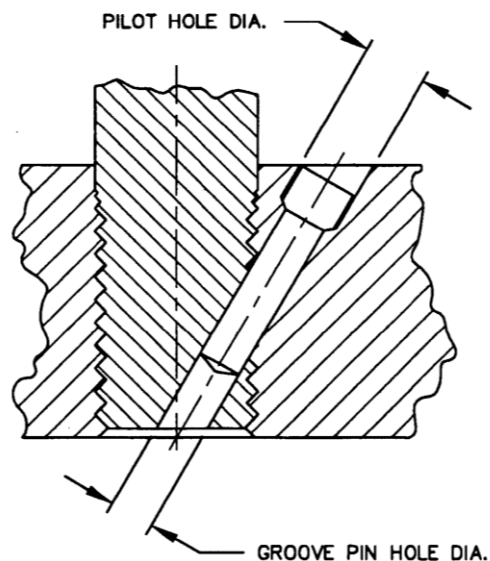

Figure 2: Groove Pin Pilot Holes

**Table 1: Stem Torque and Groove Pin Drill Sizes**

Valve Stem Connection (VSC)		Torque Min/Max Values		Groove Pin Drill Size
Inches	mm	Lbf-Ft	N•m	Inches
3/4	19.1	237-339	175-250	3/16
1	25.4	420-481	310-355	1/4

**Note:** Use a new groove pin when installing a new stem. Vibration may loosen the stem if using an old groove pin.

## Assembly

1. Ensure all gasket surfaces are clean.
2. Replace the valve plug piston ring or seal ring with a new ring.
3. Assembly for design:
  - 3.1. "CVS ED" Design Bodies:  
For valve bodies using a carbon filled TFE piston ring, at the split, slightly spread the ring and install it over the stem and into the piston ring groove on the valve plug.

Graphite piston rings are supplied as a complete ring and must be broken into two sections. The piston ring can be broken in half by scoring, and then breaking over a hard surface i.e.) edge of a table. Ensure the broken ends are re-matched when the piston ring is installed in the piston ring groove.

- 3.2. "CVS ET" Design Bodies:  
Apply a lubricant to both back-up ring and seal rings. Install the back-up ring over the stem and into the piston ring groove. Place the seal ring over the top edge of the valve plug, so that it slips into the groove on one side of the valve plug.

**Cautiously** stretch the seal ring to work it over the top edge of the valve plug. Avoid jerking sharply on the seal, as the TFE in the seal ring needs time to cold flow during the stretching procedure. This stretching procedure may make the seal ring seem loose in the groove, however it will contract to its original size after installation of the cage.

4. Replace the seat ring gasket, and install the seat ring. If using a composition seat (TFE), assemble it by placing the TFE disc onto the disc retainer and then sliding this assembly over the disc seat.

5. Place the cage onto the seat ring. Any rotational orientation of the cage with respect to the valve body is acceptable.
6. To ensure a good seal, clean all sealing surfaces and examine surfaces for nicks and scratches. Place the bonnet gasket in position.
7. Slide the valve plug assembly in the cage, and then position the load ring on top of the cage.
8. Place the bonnet on the body ensuring that the pipe plug (or lubricator) is on the downstream side of the body.
9. Using good bolting practices, bolt the bonnet to the body. Lubricate the studs and nuts using good quality lubrication. Tighten the bolts alternately. Correct tightening of the bonnet bolts accomplishes two objectives.
  - 9.1. To compress the bonnet gasket to form a seal with the body joint.
  - 9.2. Bolt loads are transmitted to the cage through the load ring, which creates a sealing load for the seat ring gasket.
10. Mount the actuator to the bonnet and make up the stem connection. Refer to "Making Up the Stem Connection" for proper procedure.

## Packing Lubrication

The use of semi-metallic packing requires the use of a lubricator or lubricator/isolating valve (Figure 3). The lubricator or lubricator/isolating valve is mounted in place of pipe plug (Figure 3, Key 15). For standard service up to 450°F, use Dow Corning lubricant or equivalent. Do not lubricate packing used in oxygen service.

**Lubricator** -To add lubricant to the packing box, turn the cap screw in a clockwise direction.

**Lubricator/Isolating Valve** - Open the isolating valve, turn the cap screw in a clockwise direction, and then close the isolating valve.

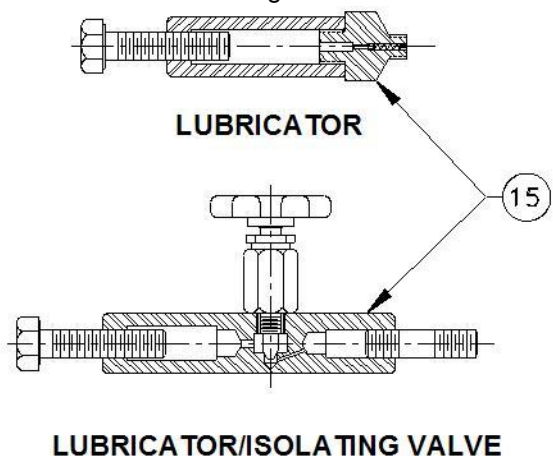

**Figure 3: Lubricator and Lubricator/Isolating Valve**

## Replacing TFE V-Ring Packing

1. After the stem and valve plug have been detached from the bonnet, the following parts can be removed:
  - 1.1. Packing nuts
  - 1.2. Packing flange
  - 1.3. Wiper ring
  - 1.4. Packing follower
2. The old packing can be removed by one of two methods:
  - 2.1. Remove the packing by pushing it out using a rod inserted through bottom of the bonnet.
  - 2.2. Use a packing hook to remove the packing.  
**Note:** To avoid damaging the packing box walls use caution.
3. Clean the packing box bore, and all metal parts. Complete all required maintenance.
4. Slide the valve plug into the cage already in the valve body, install the load ring on the cage, and use a new bonnet gasket. Mount the bonnet to the valve body.
5. Complete the installation of the packing as illustrated in Figure 4.  
  
**Note: Extra caution should be taken not to damage the packing during the installation process.**
6. Replace the packing flange (Key 27); tighten the packing flange nuts (Key 29) until shoulder of packing follower (Key 30) is approximately 5/8" from the top of the bonnet. If leakage is detected around the packing follower, tighten the packing flange nuts until leakage stops.
7. For graphite packing, tighten the packing flange nuts to the maximum torque value in Table 3. Then back off the nuts and retighten them to the minimum torque value in Table 3.

8. For other Packing Types, in small equal increments tighten the flange nuts until one of the nuts reach the minimum torque shown in Table 3. Then tighten the other nut until the packing flange is level.
9. Mount the actuator and set the stem connector to the required travel. Refer to "Making Up the Stem Connection" procedure.

## Lapping Metal Seats

In any valve body, a certain amount of leakage should be expected with metal-to-metal seating. However, if the leakage becomes excessive, lapping can enhance the condition of the seating surfaces of the valve plug and seat ring.

Deep nicks in the seating surfaces should be removed by machining rather than lapping. There are many lapping compounds available commercially. Be sure to use one of high quality.

Apply lapping compound to bottom of plug. In order to position the cage and seat ring properly and to help align the valve plug with the seat ring, bolt the bonnet to the body with gaskets (the old gaskets can be used) in place during the lapping procedure. A simple handle can be made from a piece of metal secured to the valve stem with nuts.

Rotate the handle in opposite directions to lap the seating surfaces. Once lapping is complete, disconnect bonnet, clean the seating surfaces, reassemble, and then test for shutoff. If leakage is still excessive, repeat lapping procedure.

**Table 2: Body to Bonnet Torque**

Valve Size	Bolt Torques			
	SA 193-B7, B8M <sup>a</sup>		SA-193-B8M <sup>b</sup>	
	N•m	Lbf•ft	N•m	Lbf•ft
8	746	550	529	390

a - Strain Hardened  
b - Annealed

**Table 3: Torque Values for Packing Flange Nuts**

Valve Stem Diameter		ANSI Rating	PTFE Type Packing				Graphite Type Packing			
Inches	Mm		Min. Torque		Max. Torque		Min. Torque		Max. Torque	
			Lbf-in	N•m	Lbf-in	N•m	Lbf-in	N•m	Lbf-in	N•m
3/4	19.1	150	47	5	70	8	99	11	149	17
		300	64	7	95	11	133	15	199	23
		600	87	10	131	15	182	21	274	31
1	25.4	300	108	12	162	18	226	26	339	38
		600	149	17	223	25	310	35	466	53

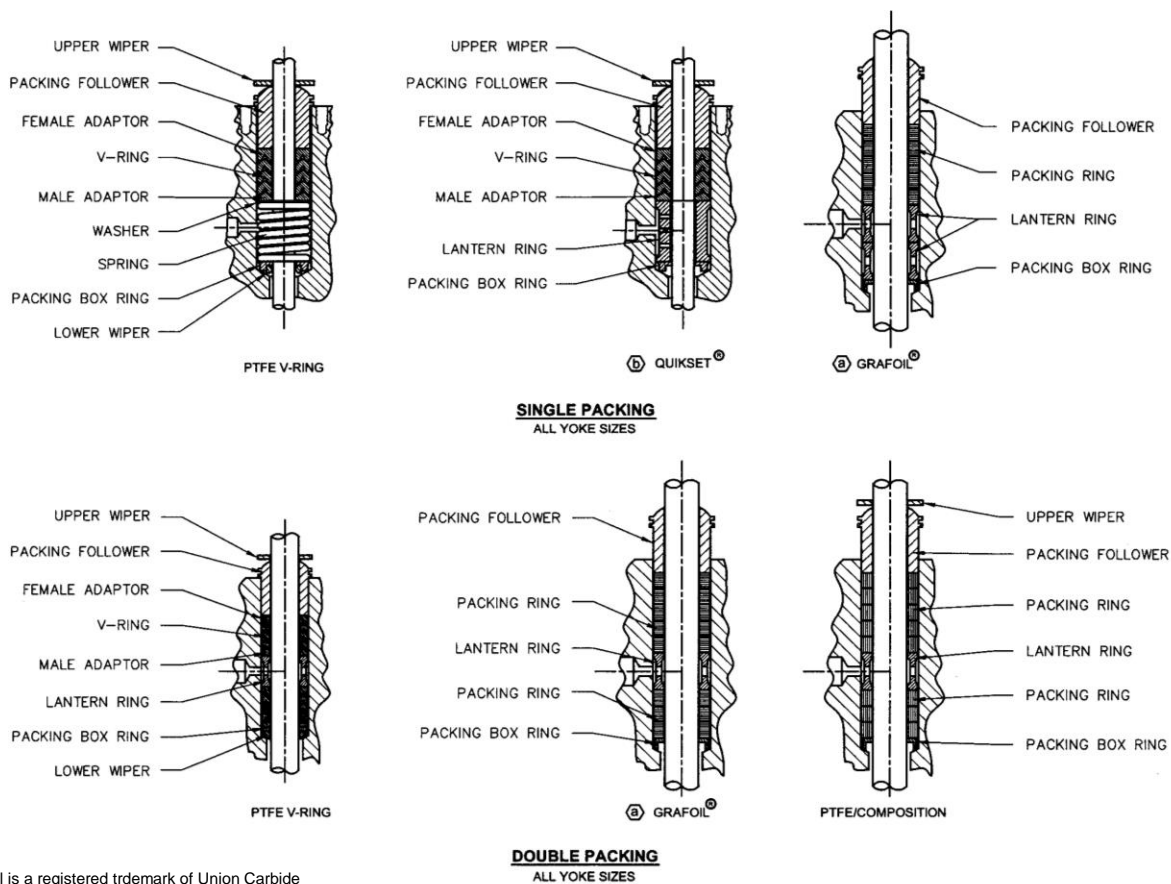

**Notes:**

- a) Grafoil is a registered trademark of Union Carbide
- b) Quikset is a registered trademark of Garlock Inc.

**Figure 4: Packing Arrangements**

**Making Up the Stem Connection**

**Direct-Acting Actuators**

1. Move the valve plug to the closed position.
2. Thread the actuator stem locknuts to the bottom of the plug stem threads. Position the travel indicator disc, cupped edge downward, over the stem. Apply enough spring force to the actuator stem to ensure the actuator is in the "full up" position.
3. Move the actuator stem to the full downward position by applying full loading pressure to the diaphragm case. Measure the distance between the lower end of the actuator stem and the travel indicator disc on the stem locknuts.
4. Slowly decrease the load on the actuator, allowing the stem to rise up approximately by 1/8". Using the two-piece stem connector and cap screws, secure the actuator stem and valve plug stem together.
5. Place the travel indicator disc against the bottom of the stem connector. Secure the disc in place with the upper locknut. Adjust the travel indicator scale so it reads "closed."

6. Relieve the diaphragm loading pressure and check for sufficient travel. i.e.) Movement of valve plug to the fully "Open" position. Tighten the lower stem locknut against the upper locknut. The connection is now complete.

To increase desired length of travel:

- a. Loosen both stem locknuts away from the stem connector by approximately 1/4" and then tighten them together.
- b. This adjustment will allow a wrench to be used on the locknuts to screw the valve plug stem to the desired position.
- c. *Caution:* ensure that the valve plug is not seated while being rotated. Do not exceed the 1/8" adjustment made in Step 4.
- d. Retighten the stem connector and locknuts after adjustment.
- e. Reposition the travel indicator scale to reflect the change.

## **Making Up the Stem Connection**

### **Reverse-Acting Actuators**

1. Close the valve plug ensuring the valve plug is on the seat.
2. Supply enough spring force to the actuator stem to ensure the actuator is in full "Down" position. Increase the loading pressure to the diaphragm case to allow the actuator stem to rise sufficiently so the locknuts can be screwed onto the valve plug stem. Thread the locknuts down on the valve plug stem as far as possible. Set the travel indicator on the locknuts, "cupped" edge downward.
3. Slowly release the pressure in the diaphragm case, allowing the actuator to return to the full down position. Measure the distance between the lower end of the actuator stem and the travel indicator disc.
4. Increase the load on the actuator, causing the stem to rise up by approximately 1/8". Using the two-piece stem connector and cap screws, secure the actuator stem and valve plug stem together.
5. Move the travel indicator disc against the bottom of the stem connector.
6. Secure the disc with the upper locknut. Change the travel indicator scale so that it reads closed.
7. Open the valve plug by increasing the diaphragm loading pressure. Secure the lower stem locknut against the upper locknut. The connection is now complete.
8. To increase travel see "To increase desired length of travel" instructions.

### **Parts Ordering**

A serial number identifies every CVS Series E valve body-bonnet assembly, which can be found on the front of the valve. Please refer to this number when contacting your CVS Controls representative.

# CVS Series E 8-inch Globe Valves

## Parts Reference

Key	Part Name
1	Valve Plug Stem
2	Body
3	Bonnet Gasket
4	Load Ring
5	Groove Pin
6	Valve Plug
7	Seat Ring
8	Flow Arrow
9	Hex Nut
10	Stud Bolt or Cap Screw
11	Piston Ring (Design ED Only)
13	Cage

Key	Part Name
14	Seat Ring Gasket
15	Pipe Plug
16	Drive Screw
17	Disc Retainer (Soft Seat Only)
18	Disc Seat (Soft Seat Only)
19	Seal Ring (Design ET Only)
20	Disc (Soft Seat Only)
21	Packing Ring
22	Bonnet
23	Pipe Plug
24	Packing Spring / Lantern Ring
25	Special Washer

Key	Part Name
26	Upper Wiper
27	Packing Flange
28	Stud
29	Nut
30	Packing Follower
31	Locknut (3-9/16" Yoke Boss Only)
32	Packing Set
33	Pipe Plug
34	Packing Box Ring
35	Cap Screw (5" Yoke Boss Only)
36	Nut (5" Yoke Boss Only)

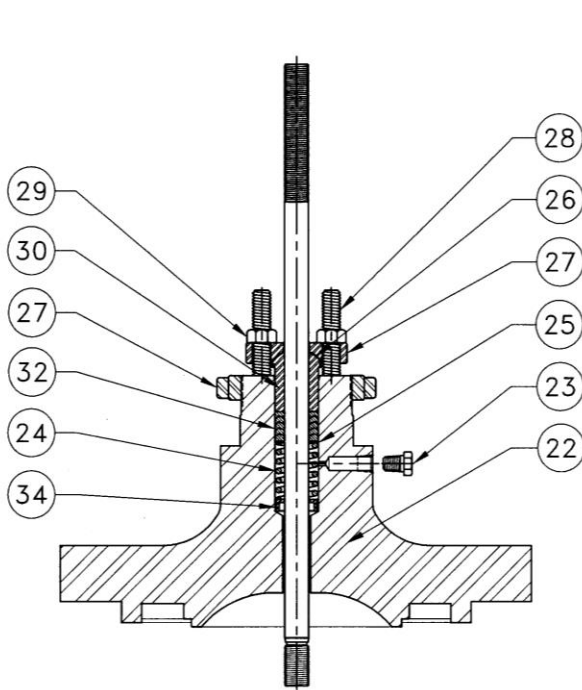

Standard Bonnet  
3-9/16" Yoke Boss, 3/4" Stem

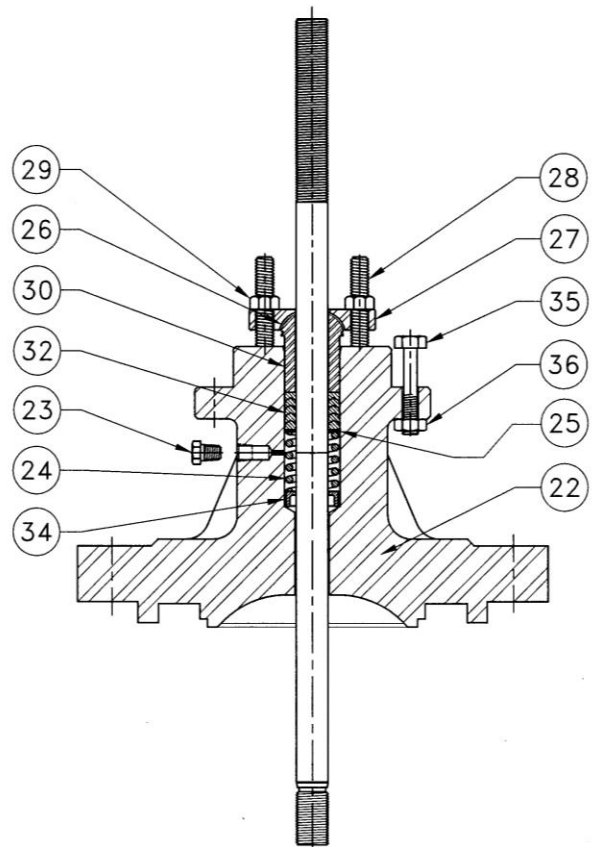

Extension Bonnet  
5" Yoke Boss, 1" Stem

Figure 5: Bonnet Assemblies, CVS Series E 8" Globe Valves,

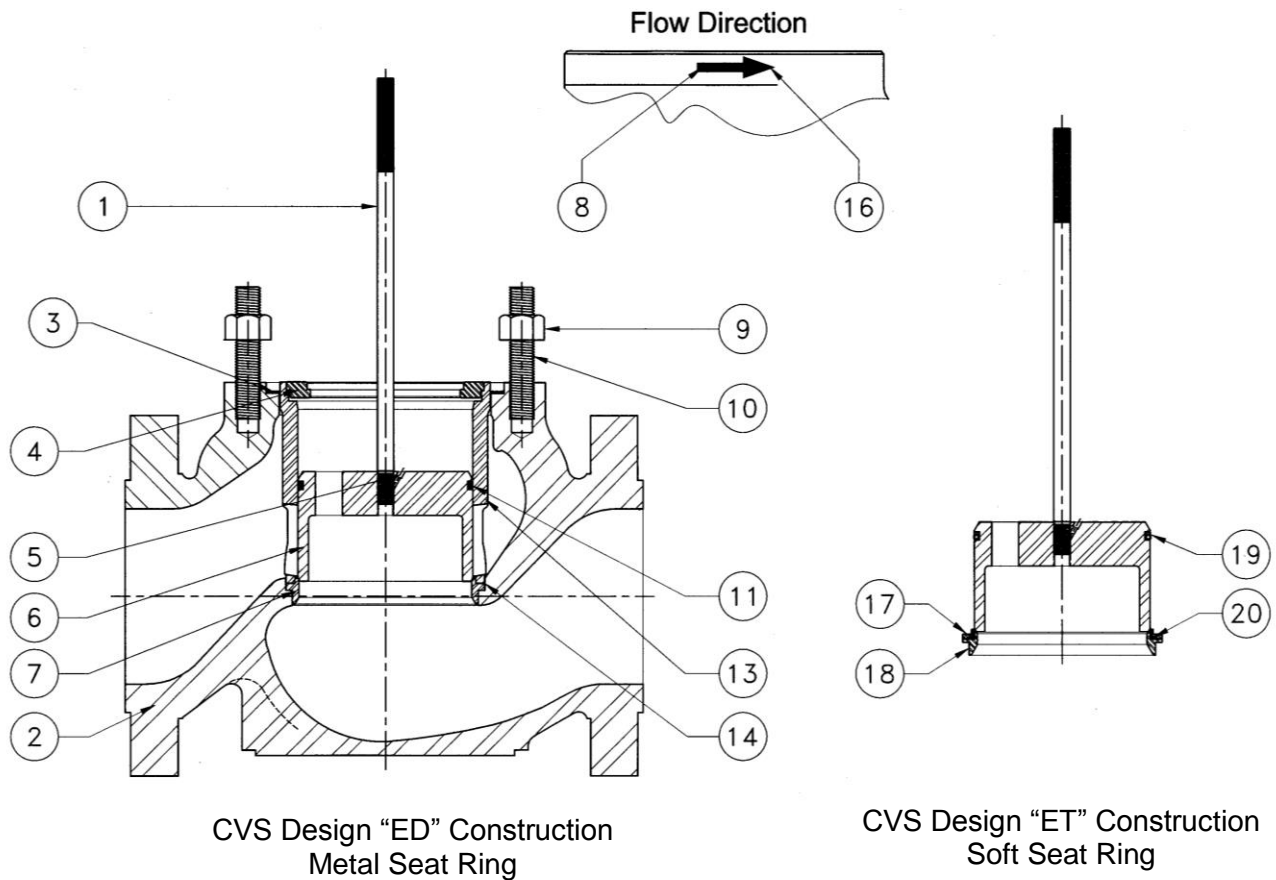

CVS Design "ED" Construction  
Metal Seat Ring

CVS Design "ET" Construction  
Soft Seat Ring

Figure 6: Body Assemblies, CVS Series E 8" Globe Valves,

## CVS Series E 8-inch Globe Valves

### Parts Reference

Key	Description	Part Number	
1	Valve Plug Stem, 316 SST	See Following Table	
2	Valve Body	See Following Table	
3	Bonnet Gasket	Metal Seat -425°F to 800°F (-254°C to 427°C), material Over 800°F (427°C), Laminated Graphite	CVS10A3265X012
		Composition Seat, Nitrile	CVS10A3265X032
4	Load Ring	-150°F to 600°F (-101°C to 316°C), 17-4PH SST	CVS20A3267X012
		-425°F to 1100°F (-254°C to 593°C), Inconel 718	CVS20A3267X022
		-400°F to 500°F (-240°C to 260°C), Corrosive Service, K Monel	CVS20A3268X012
5	Groove Pin, 316 SST	3/4" VSC (19.1 mm)	CVS1V326035072
		1" VSC (25.4 mm)	CVS1V334035072
6	Valve Plug	See Following Table	
7	Seat Ring	416 SST	CVS20A3260X012
		Alloy 6	CVS20A3260X152
8	Flow Arrow, SST	CVS1V106038982	
9	Hex Nut, Steel (16 req'd), Steel Bodies Only	CVS1A445224072	
10	Stud Bolt, Steel (16 req'd)	CVS1D945231012	



Key	Description		Part Number	
11	Piston Ring, Graphite, Design ED Only	Non-Oxidizing Service	CVS10A3262X012	
		Oxidizing Service	CVS10A3262X022	
13	Cage	Equal Percentage	17-PH SST	CVS20A3245X012
			316 SST Ni Coated	CVS20A5467X012
			316 SST CR PL	CVS20A4348X012
			17-PH SST	CVS20A3247X012
		Linear	316 SST Ni Coated	CVS20A5468X012
			316 SST CR PL	CVS20A4349X012
		Quick Opening	17-PH SST	CVS20A3249X012
			316 SST Ni Coated	CVS20A5469X012
14	Seat Ring, Gasket, Metal Seat	Metal Seat	-425°F to 800°F (-254°C to 427°C), material Over 800°F (427°C), Laminated Graphite	
		Composition Seat, Nitrile	CVS10A3266X032	
15	Pipe Plug	Steel (LCC & WCB Bodies)	CVS1A771528992	
		316 SST (316 SST Bodies)	CVS1A771535072	
16	Drive Screw (2 req'd), CD PL Steel		CVS1A368228982	
17	Disc Retainer, 316 SST, Composition Seats Only		CVS10A4466X012	
18	Disc Seat, 316, Composition Seats Only		CVS20A4467X012	
19	Seal Ring, TFE, Spring Loaded, -100°F to 450°F (-73°C to 232°C), Design ET Only		CVS10A3261X012	
20	Disc, TFE, -70°F to 400°F (-57°C to 204°C), Composition Seats Only		CVS20A4468X012	
21	Packing Ring	Graphite (2 req'd)	3/4" Stem (19.1 mm)	CVS1D749001052
			1" Stem (25.4 mm)	CVS1D751801052
		TFE (8 req'd)	3/4" Stem (19.1 mm)	CVS1E319101042
			1" Stem (25.4 mm)	CVS1D7518X0012
		Laminated Graphite (4 req'd)	3/4" Stem (19.1 mm)	CVS1V239601652
			1" Stem (25.4 mm)	CVS1U676801652
22	Bonnet		See Following Table	
23	Pipe Plug (Tapped Extension Bonnets Only)	Steel (Steel Bonnets)	CVS1A767524662	
		316 SST (316 SST Bonnets)	CVS1A767535072	
24	Spring, 316 SST (TFE V-Ring Packing Only)	3/4" Stem (19.1 mm)	CVS1F125637012	
		1" Stem (25.4 mm)	CVS1D582937012	
		Lantern Ring, 316 SST (Laminated Graphite Packing, 2 req'd, Other Packing, 1 req'd)	3/4" Stem (19.1 mm)	CVS0N028435072
25	Special Washer, 316 SST (TFE V-Ring Packing Only)	1" Stem (25.4 mm)	CVS0U099735072	
		3/4" Stem (19.1 mm)	CVS1F125036042	
26	Upper Wiper, Felt (Not req'd for Laminated Graphite Packing)	3/4" Stem (19.1 mm)	CVS1H982236042	
		1" Stem (25.4 mm)	CVS1J872806332	
27	Packing Flange, Steel	3/4" Stem (19.1 mm)	CVS1J872906332	
		1" Stem (25.4 mm)	CVS1E944823072	
28	Stud, Steel (2 req'd)	3/4" Stem (19.1 mm)	CVS0V002425052	
		1" Stem (25.4 mm)	CVS1E944931032	
29	Nut, Steel (2 req'd)	3/4" Stem (19.1 mm)	CVS0V002531032	
		1" Stem (25.4 mm)	CVS1E944624112	
30	Packing Follower, 316 SST	3/4" Stem (19.1 mm)	CVS1L692124112	
		1" Stem (25.4 mm)	CVS1E944735072	
31	Locknut, Steel (3-9/16" Yoke Boss Only)	3/4" Stem (19.1 mm)	CVS1H982335072	
		1" Stem (25.4 mm)	CVS1E832723062	
32	Packing Set, TFE V-Ring (Includes male adaptor, female adaptor, lower wiper and three packing rings)	3/4" Stem (19.1 mm)	CVS1R290401012	
		1" Stem (25.4 mm)	CVS1R290601012	
33	Pipe Plug	Steel (Steel Bonnets)	CVS1A767524662	
		316 SST (316 SST Bonnets)	CVS1A767535072	
34	Packing Box Ring, 17-4PH SST	3/4" Stem (19.1 mm)	CVS1J873335012	
		1" Stem (25.4 mm)	CVS1J873435012	
35	Cap Screw, Steel (8 req'd) (5" Yoke Boss only)		CVS1A936224052	
36	Nut, Steel (8 req'd) (5" Yoke Boss only)		CVS1A343324122	

**Key 1: Valve Plug Stem**

Stem Size		Valve Stem Connection		Specifications	Part Number	
In	mm	In	mm			
3/4	19.1	3/4	19.1	Plain Bonnet, 19-3/8" Stem	CVS1K588035162	
				Style 1 Extension Bonnet, 21" Stem	CVS1U928235162	
1	25.4	1	25.4	Style 1 Extension Bonnet	657 Actuator 2" Travel, 24-3/16" Stem	CVS1K7891X0012
					3" Travel, 23-3/16" Stem	CVS10A3282X012
					667 Actuator, 2" – 3" Travel, 23-3/16" Stem	CVS10A3282X012

**Key 2: Valve Body**

End Connection		Steel (LCC)	Steel (WCB)	316 SST
<b>Without Drain Plug Tapping</b>				
RF Flg	150 lb	CVS30A3224LX012	CVS30A3224WX012	CVS30A3224X062
	300 lb	CVS30A3225LX012	CVS30A3225WX012	CVS30A3225X062
	600 lb	CVS30A3226LX012	CVS30A3226WX012	CVS30A3226X062
RTJ Flg	150 lb	CVS30A3227LX012	CVS30A3227WX012	CVS30A3227X062
	300 lb	CVS30A3228LX012	CVS30A3228WX012	CVS30A3228X062
	600 lb	CVS30A3229LX012	CVS30A3229WX012	CVS30A3229X062
Butt Weld	Sch 40	CVS30A3222LX012	CVS30A3222WX012	CVS30A3222X062
	Sch 80	CVS30A3223LX012	CVS30A3223WX012	CVS30A3223X062
<b>With Drain Plug Tapping</b>				
RF Flg	150 lb	CVS30A3232LX012	CVS30A3232WX012	CVS30A3232X062
	300 lb	CVS30A3233LX012	CVS30A3233WX012	CVS30A3233X062
	600 lb	CVS30A3234LX012	CVS30A3234WX012	CVS30A3234X062
RTJ Flg	150 lb	CVS30A3235LX012	CVS30A3235WX012	CVS30A3235X062
	300 lb	CVS30A3236LX012	CVS30A3236WX012	CVS30A3236X062
	600 lb	CVS30A3237LX012	CVS30A3237WX012	CVS30A3237X062
Butt Weld	Sch 40	CVS30A3230LX012	CVS30A3230WX012	CVS30A3230X062
	Sch 80	CVS30A3231LX012	CVS30A3231WX012	CVS30A3231X062

**Key 6: Valve Plug**

Stem Size		Valve Stem Connection		Material		
In	mm	In	mm	416 SST Hardened	316 SST	316 SST Hard Faced Seat & Guide
3/4	19.1	3/4	19.1	CVS21A5356X012	CVS21A5356X022	CVS21A5362X012
1	25.4	1	25.4	CVS21A5356X012	CVS21A5357X022	CVS21A5363X012

**Key 22 Bonnet, Same material as body**

Material	Style		3-9/16" Yoke Boss 3/4" Stem	5" Yoke Boss 1" Stem
Steel	Plain		CVS30A5471X012	---
	Style 1 Extension	Tapped	CVS30A3279X012	CVS30A3280X012
		Untapped	CVS30A3270X012	CVS30A3274X012
316 SST	Style 1 Extension	Tapped	CVS30A3279X062	CVS30A3280X062
		Untapped	CVS30A3270X062	CVS30A3274X062

# CVS Series E 8-inch Globe Valves

## Dimensional Data

### End Connection Style

VALVE SIZE		DIMENSION "A"											
		150 RF		150 RTJ		300 RF		300 RTJ		600 RF		600 RTJ	
In	mm	In	mm	In	mm	In	mm	In	mm	In	mm	In	mm
8	203	21.38	543	21.88	556	22.38	568	23.00	584	24.00	610	24.12	613

\* - Dimension B=DimA/2

VALVE SIZE		DIMENSION "D" STANDARD BONNET		DIMENSION "D" EXTENSION BONNET		DIMENSION "C" Max	
		STEM DIAMETER		STEM DIAMETER			
In	mm	3/4 Inch	19.1 mm	3/4 Inch	19.1 mm	Inch	mm
8	203	14.75	375	16.56	421	7.50	191

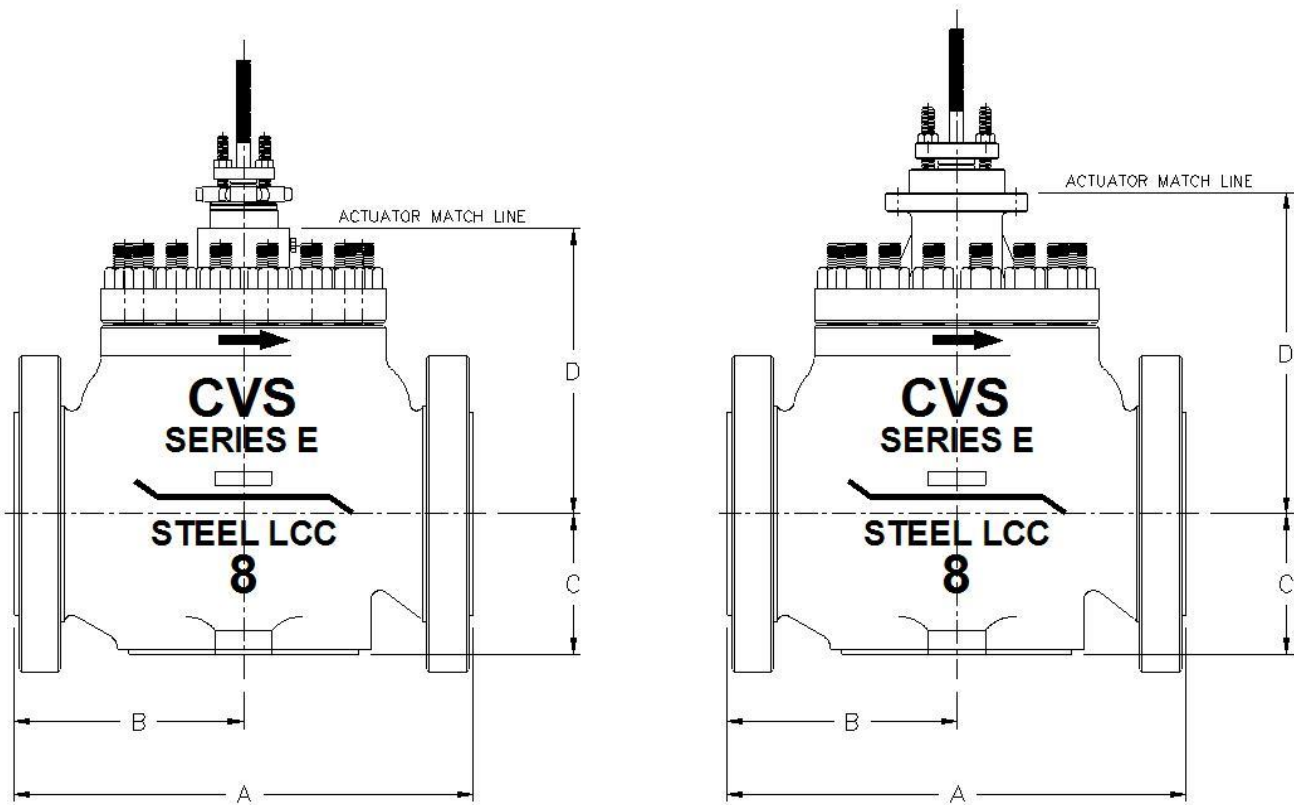

Approximate shipping weight: 408kg (900lbs)

# CVS Series E, 8 Inch, Design ED and Design ET – Product Bulletin

## Flow Coefficients

### Quick Opening - CVS Design ED

Valve Size, NPS	Port Diameter		Maximum Travel		Flow Coefficient	C <sub>v</sub> for .25 Inch (6mm) Travel	Valve Opening—Percent of Total Travel										FL <sup>(1)</sup>
	Inches	mm	Inches	mm			10	20	30	40	50	60	70	80	90	100	
8	8	203.2	2	51	Cv	108	80.3	188	290	389	480	554	615	658	705	744	0.87
					Kv	93.4	69.5	163	251	336	415	479	532	569	610	644	---
					Xt	0.653	0.670	0.628	0.679	0.731	0.766	0.806	0.829	0.859	0.863	0.866	---
8	8	203.2	3	76	Cv	108	135	291	434	551	639	706	759	807	841	863	0.85
					Kv	93.4	117	252	375	477	553	611	657	698	727	746	---
					Xt	0.653	0.643	0.699	0.757	0.807	0.838	0.861	0.857	0.841	0.838	0.827	---
					Fd	---	0.19	0.24	0.26	0.27	0.28	0.28	0.28	0.28	0.28	0.28	0.27

1. At 100% travel

### Linear – CVS Design ED

Valve Size, NPS	Port Diameter		Maximum Travel		Flow Coefficient	Valve Opening—Percent of Total Travel										FL <sup>(1)</sup>
	Inches	mm	Inches	mm		10	20	30	40	50	60	70	80	90	100	
8	8	203.2	2	51	Cv	60.2	129	206	285	363	444	526	581	640	688	0.87
					Kv	52.1	112	178	247	314	384	455	503	554	595	---
					Xt	0.7404	0.721	0.657	0.651	0.683	0.713	0.740	0.801	0.821	0.839	---
8	8	203.2	3	76	Cv	91.4	207	325	440	550	639	711	760	795	846	0.87
					Kv	79.1	179	281	381	476	553	615	657	688	732	---
					Xt	0.651	0.624	0.677	0.746	0.786	0.803	0.823	0.836	0.843	0.807	---
					Fd	0.23	0.28	0.30	0.31	0.31	0.31	0.31	0.31	0.31	0.31	0.31

1. At 100% travel.

## CVS Series E, 8 Inch, Design ED and Design ET – Product Bulletin

### Flow Coefficients

#### Equal Percent – CVS Design ED, Flow Down

Valve Size, NPS	Port Diameter		Maximum Travel		Flow Coefficient	Valve Opening—Percent of Total Travel										FL <sup>(1)</sup>
	Inches	mm	Inches	mm		10	20	30	40	50	60	70	80	90	100	
8	8	203.2	2	51	Cv	18.5	38.0	58.4	86.7	130	189	268	371	476	567	0.85
					Kv	16.0	32.9	50.5	75.0	112	163	232	321	412	490	---
					Xt	0.727	0.623	0.600	0.588	0.580	0.587	0.599	0.611	0.671	0.725	---
8	8	203.2	3	76	Cv	27.0	58.1	105	188	307	478	605	695	761	818	0.86
					Kv	23.4	50.3	90.8	163	266	413	523	601	658	708	---
					Xt	0.644	0.654	0.636	0.611	0.643	0.15	0.725	0.809	0.804	0.807	---
					Fd	0.28	0.26	0.23	0.20	0.17	0.22	0.24	0.25	0.25	0.26	---

1. At 100% travel.

#### Noise Abatement 1 – Flow Up, CVS Design ED

#### Linear Characteristic

Valve Size, NPS	Port Diameter		Maximum Travel		Flow Coefficient	Valve Opening—Percent of Total Travel									
	Inches	mm	Inches	mm		10	20	30	40	50	60	70	80	90	100
8	8	203.2	3 <sup>(1)</sup>	76 <sup>(1)</sup>	Cv	100	226	337	436	502	581	641	655	659	681
					Kv	86.5	195	292	377	434	503	554	567	570	589
					Xt	0.456	0.490	0.470	0.427	0.452	0.468	0.521	0.624	0.703	0.701
8	8	203.2	4	102	Cv	142	303	428	542	611	652	669	689	700	726
					Kv	123	262	370	469	529	564	579	596	606	628
					Xt	0.549	0.450	0.436	0.441	0.513	0.624	0.707	0.709	0.729	0.718

1. Travel is limited to 2.75 in with a Class IV CVS ED valve plug.

# CVS Series E, 8 Inch, Design ED and Design ET – Product Bulletin

## Flow Coefficients

### Quick Opening - CVS Design ET

Valve Size, NPS	Port Diameter		Maximum Travel		Flow Coefficient	C <sub>v</sub> for .25 Inch (6mm) Travel	Valve Opening—Percent of Total Travel										FL <sup>(1)</sup>
	Inches	mm	Inches	mm			10	20	30	40	50	60	70	80	90	100	
8	8	203.2	2	51	Cv	108	80.3	188	290	389	480	554	615	658	705	744	0.87
					Kv	93.4	69.5	163	251	336	415	479	532	469	610	644	---
					Xt	0.653	0.670	0.628	0.679	0.731	0.766	0.806	0.829	0.859	0.863	0.866	---
8	8	203.2	3	76	Cv	108	135	291	434	551	639	706	759	807	841	863	0.85
					Kv	93.4	117	252	375	477	553	611	657	698	727	746	---
					Xt	0.653	0.643	0.699	0.757	0.807	0.838	0.861	0.857	0.841	0.838	0.827	---
					Fd	---	0.19	0.24	0.26	0.27	0.28	0.28	0.28	0.28	0.28	0.28	0.27

1. At 100% travel

### Linear – CVS Design ET

Valve Size, NPS	Port Diameter		Maximum Travel		Flow Coefficient	Valve Opening—Percent of Total Travel										FL <sup>(1)</sup>
	Inches	mm	Inches	mm		10	20	30	40	50	60	70	80	90	100	
8	8	203.2	2	51	Cv	60.2	129	206	285	363	444	526	581	640	688	0.87
					Kv	52.1	112	178	247	314	384	455	503	554	595	---
					Xt	0.704	0.721	0.657	0.651	0.683	0.713	0.740	0.801	0.821	0.839	---
8	8	203.2	3	76	Cv	91.4	207	325	440	550	639	711	760	795	846	0.87
					Kv	79.1	179	281	381	476	553	615	657	688	732	---
					Xt	0.651	0.624	0.677	0.746	0.786	0.803	0.823	0.836	0.843	0.807	---
					Fd	0.23	0.28	0.30	0.31	0.31	0.31	0.31	0.31	0.31	0.31	0.31

1. At 100% travel.

## CVS Series E, 8 Inch, Design ED and Design ET – Product Bulletin

### Flow Coefficients

#### Equal Percent – CVS Design ET

Valve Size, NPS	Port Diameter		Maximum Travel		Flow Coefficient	Valve Opening—Percent of Total Travel										FL <sup>(1)</sup>
	Inches	mm	Inches	mm		10	20	30	40	50	60	70	80	90	100	
8	8	203.2	2	51	Cv	18.5	38.0	58.4	86.7	130	189	268	371	476	567	0.85
					Kv	16.0	32.9	50.5	75.0	112	163	232	321	412	490	---
					Xt	.0727	0.623	0.600	0.588	0.580	0.587	0.599	0.611	0.671	0.724	---
8	8	203.2	3	76	Cv	27.0	58.1	105	188	307	478	605	695	761	818	0.86
					Kv	23.4	50.3	90.8	163	266	413	523	601	658	708	---
					Xt	0.644	0.654	0.636	0.611	0.643	0.615	0.725	0.809	0.804	0.807	---
					Fd	0.28	0.26	0.23	0.20	0.17	0.22	0.24	0.25	0.25	0.26	---

1. At 100% travel.

### Shutoff Classifications

Valve Design	Series ET		Series ED	
	Seating	Shutoff Class	Standard	Optional
All valve designs with the exception of Anti-Cav III cages	PTFE (standard)	IV Standard	Class II	Class III, Valves with Graphite
		V (optional)		
ET with Anti-Cav III Single Stage cage	Metal	IV		
		V (optional)		
ET with Anti-Cav III two stage cage	Metal	IV Standard		
		V (optional)		
		V		

### Flow Characteristics

- Linear, Quick Opening or Equal Percent

### Flow Directions

- **Normally Down**, Linear, Quick Opening, Equal Percent
- **Always Up**, Noise Abatement
- **Always Down**, Anti-Cav

# CVS

---

## CONTROLS

### **Head Office**

3900 – 101 Street  
Edmonton, Alberta, Canada T6E 0A5  
Office: (780) 437-3055  
Fax: (780) 436-5461

### **Calgary Sales Office**

3516 114 Avenue SE  
Calgary, Alberta, Canada T2Z 3V6  
Office: (403) 250-1416  
Fax: (403) 291-9487

Website: [www.cvs-controls.com](http://www.cvs-controls.com) E-Mail: [info@cvs-controls.com](mailto:info@cvs-controls.com)