

CVS Self Contained Hydraulic Pump

Introduction

This CVS Controls product manual includes instructions for the installation, adjustment, maintenance and parts ordering of the CVS Self Contained Pump.

All CVS Controls equipment should be installed, operated and maintained by qualified personnel. If you have any questions regarding this equipment, contact your CVS Controls representative.

Description

The CVS Self Contained Pump provides reliable emergency shutdown when an external power source or fuel gas is not available or not reliable. The unit uses clean hydraulic fluid.

Used in conjunction with a linear or rotary spring return hydraulic operator, the CVS Self Contained Pump is a fail-safe system which is suitable for ball, plug or other quarter-turn valves as well as reverse-acting gate valves or other linear operated valves.

This pump has been proven reliable under the most demanding operating and environmental conditions. It is designed to be the foundation for a flexible sensing and control system, and has built-in temperature compensation and pressure relief.

Figure 1: CVS Self Contained Hydraulic Pump



Installation

Generally, the module is installed on the operator by CVS Controls at the manufacturing facility, but can also be field installed by the user.

The module can be ordered in pressure configurations from 100 psi to 2250 psi.

The following connections are marked on the manifold assembly:

- H: High pressure hydraulic supply to operator
- L: Low pressure hydraulic supply for monitoring devices
- S: Low pressure hydraulic signal for RESET VALVE from monitoring or ESD devices
- V: Vent or return line to allow off-panel devices to return oil to the reservoir

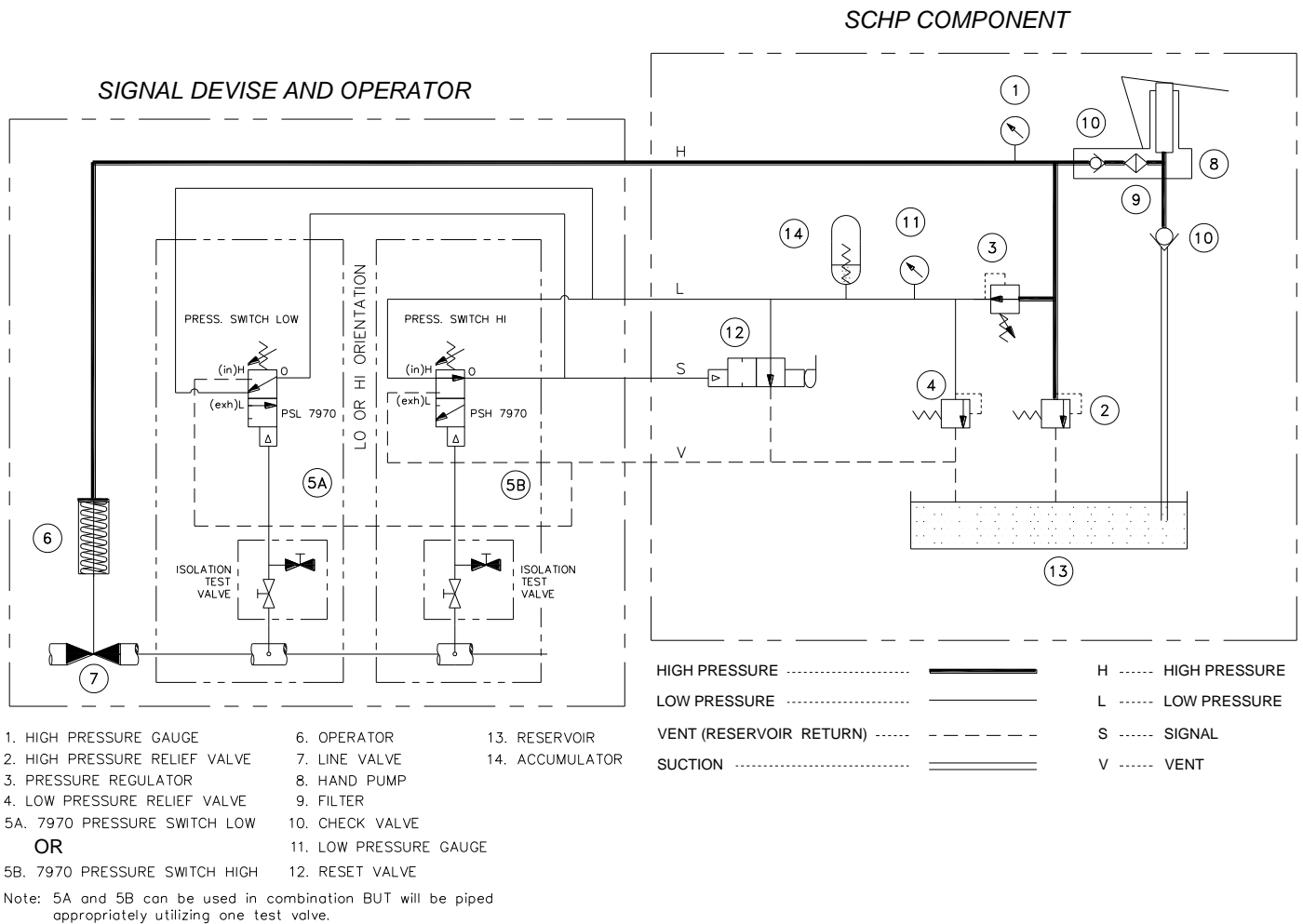

Figure 2: Module Schematic

This example illustrates the operating method and options for sensing and control.

The module is shown with the line valve closed and reset valve unlatched.

To operate in this configuration:

Latch the reset valve (Key 12), then open the line valve (Key 7) by operating the hand pump (Key 8)

When the pilot (Key 5a or 5b) senses that pressure is within the set points the system enters automatic mode

The line valve (Key 7) will close if:

1. the reset valve (Key 12) is switched manually, or
2. the pilot (Key 5a or 5b) senses that the pressure is out of range

Specifications

Components	High-pressure SCH Module	<ul style="list-style-type: none"> ▪ HP-2-SC or BHP 3 Handpump ▪ 0-3000 PSI HP Gauge ▪ 0-200 PSI LP Gauge
	Low-pressure SCH Module	<ul style="list-style-type: none"> ▪ HP-2-SC Handpump ▪ 0-200 PSI LP Gauge
Pressure Settings	High-pressure SCH Module	<ul style="list-style-type: none"> ▪ HP Relief set at 2250 psi ▪ LP Relief set at 135 psi ▪ CVS SCR Regulator set at 80-100 psi¹
	Low-pressure SCH Module	LP Relief set at 125 psi
Valves	<ul style="list-style-type: none"> ▪ Pilot to close valve ▪ Reset valve ▪ Toggle valve ▪ Manual pilot valve (requires 40-60 psi on signal port to sustain auto mode) 	
Optional Solenoid Valve	Voltage as specified by user <ul style="list-style-type: none"> ▪ 12-24 VDC ▪ 120VAC with MAWP 150 psi 	
Valve Operator	Refer to appropriate manual for specifications	
Reservoir	Low temperature, high impact resin standard (Lexan) Cast aluminum optional.	
Other Components	High/low pressure pilot upper block is connected to the self contained hydraulic module with an operating pressure of 60 to 90 psi. Process sensing pressure MAWP depends on the manufacturer.	
¹ . Set to 90 psi at point of manufacturing		

Installation continued

Refer to Figure 2 for connections, which are also tagged at the factory. If requested, an optional Solenoid valve may have been installed and tubed at the factory and is ready for electrical connection. A metal or plastic plug may have been installed in the breather/fill port of the reservoir. If that is the case, remove the plug and replace with the breather provided in the bag attached to the unit.

Hydraulic fluid used is Esso Unavis J13 unless an alternate is specifically requested.

Operation

Manual Mode (Start Up or Reset)

1. Lift the toggle on the manual pilot valve and latch in the "Up" position. See Figure 3 for "Manual Reset" position.
2. Operate hand pump to open/close line until system is pressurized.
3. Stop pumping when high pressure gauge reading is 10% above the minimum value required to hold the valve in position.

Note

System will automatically reset at set pressure.

Note

To start up when the system is not completely connected, plug "L" Low Pressure to prevent fluid flow off the panel. Refer to operation instructions above.

Automatic Mode (To Run)

4. Lower the toggle on the manual pilot valve. See Figure 3 for "Auto/Run" position. The toggle should automatically go to "Run".
5. When the signal device(s) is satisfied, the unit will be in automatic mode. The optional Solenoid valve is returned to normal operating condition (either energized or de-energized).

Shutdown

If the pilot detects pressures outside of the set points, (or if there is an applied or removed electrical signal to the optional Solenoid valve), the pilot removes the signal to the manual pilot valve. The manual pilot valve then switches which allows the spring in the operator to stroke the line valve to the failsafe position.

The pilot can also be shutdown manually by pushing the toggle.

Maintenance

Note:

Regular maintenance should be performed monthly, or as required. CVS Controls recommends the use of protective clothing, gloves and eyewear when performing any installation or maintenance.

1. Empty fluid reservoir of any accumulated moisture.
2. Check filter element(s) and clean and/or replace as necessary.
3. Check set points on pressure relief valve(s) and reset values if required.
4. If possible, check operation and calibration of pressure pilot or optional Solenoid.
5. Top up hydraulic fluid. Be sure to use compatible fluid.

Troubleshooting

Note

As shown in Figure 2, the high-pressure side of the system supplies the low-pressure regulated side, therefore any leakage on the low side will cause significant changes in high-pressure gauge values.

Without cycling the actuator, but with the pressurized removal of the reservoir and off panel device, vent/return lines will assist in tracing leakage. To trace leakage:

1. Disconnect the vent line from the pilot/solenoid vent port. This isolates it from the SCH module and allows for checking oil leakage throughout the device.

Note

This procedure also checks o-ring seals of poppet/spool and spool/sleeve in operating positions.

2. Remove reservoir from the module and check for oil leakage of reliefs and reset valve under operating conditions.

3. Remove the filter plug, spring and filter in hand pump sub-plate to observe backside of HP discharge. Check for leakage across and around it while applying high pressure.
4. Remove fitting and tubing or plug from the second vent port of the module. Check for oil leakage that may be caused by manifold porosity between low-pressure (LP) channel and vent (V) channel.
5. Remove operator inspection cover or plate, and/or tubing from the cylinder plate to check for oil leakage across the piston seal and the piston centre o-ring.

In the case of pumping problems, access the pump suction valve by removing the pump assembly from the sub-plate. Pumping difficulties are usually caused by a dirty filter element, contaminated oil (with water or methanol), or using incorrect fluid in the unit.

When the unit fails to regulate it is noticeable by a low pressure gauge reading of 130 psi after two strokes. Service the regulator according to the appropriate maintenance manual.

Note

Before removing or disassembling any components on the manifold, depressurize the system.

Parts Ordering

All pertinent information regarding the CVS Self Contained Pump is stamped on the manifold assembly. Please refer to this information when corresponding with CVS Controls regarding parts or service.

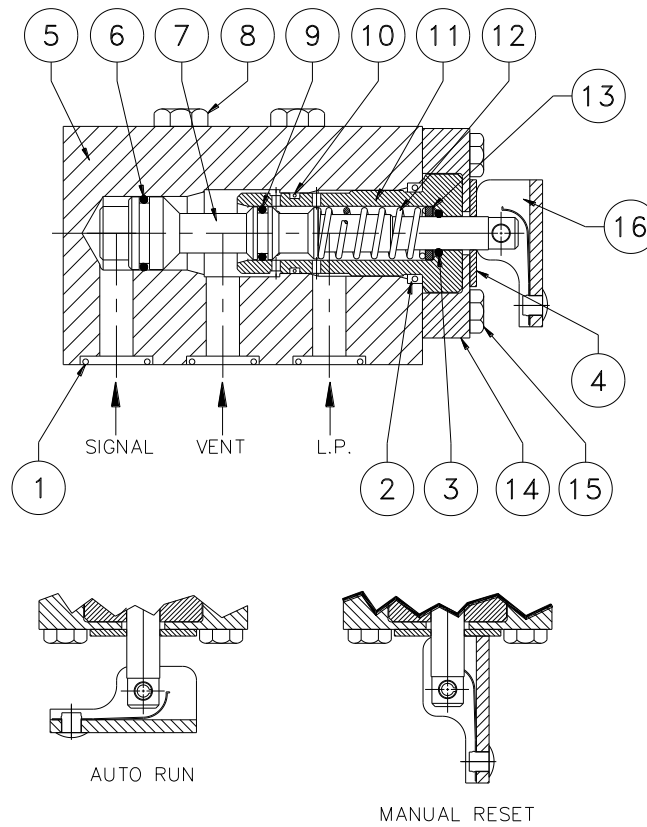

Figure 3: Reset Valve

Parts List

Key No.	Description	Material	Part Number	Qty
1	O-Ring, Reset Valve	Nitrile	Seal Kit	3*
2	O-Ring, Sleeve Head	Nitrile	Seal Kit	1*
3	O-Ring, Sleeve Stem	Nitrile	Seal Kit	1*
4	Washer Toggle	Nylon	CVSSCHARV004	1*
5	Body, Reset Valve	AL 6061-T6	CVSSCHARV001	1
6	O-Ring, Spool Piston	Nitrile	Seal Kit	1*
7	Spool, Reset Valve	AL 6061-T6	CVSSCHARV003	1
8	Capscrew, Reset Valve	SS 304	Bolt Kit	3
9	O-Ring, Spool	Nitrile	Seal Kit	1*
10	O-Ring, Sleeve	Nitrile	Seal Kit	1*
11	Sleeve, Reset Valve	Teflon	CVSSCHARV007	1
12	Spring, Reset Valve	SS 302	CVSSCHARV005	1
13	Washer, Spring	AL 6061-T6	CVSSCHARV006	1
14	Sleeve Retainer	AL 6061-T6	CVSSCHARV002	1
15	Capscrew, Sleeve Retainer	SS	Bolt Kit	2
16	Toggle Assembly	AL 6061-T6 / SS 3001	CVSSCHARV008	1

1. * Recommended Spare Part. Included in Seal Kit (CVS SCHA Seal Kit)

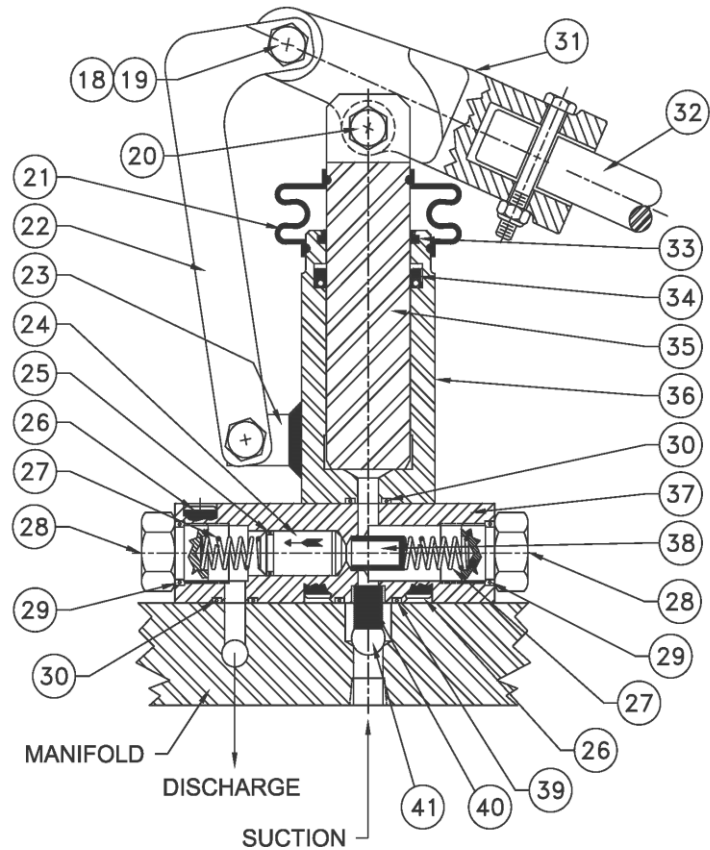

Figure 4. Hand Pump

Parts List

Key No.	Description	Material	Part Number	Qty
18	Locknut	HEXN ZN PL	Bolt Kit	3
19	Pin, Connecting Link	HXHC GR 5 ZN PL	Bolt Kit	2
20	Pin, Ram	HXHC GR 5 ZN PL	Bolt Kit	1
21	Boot		CVS SCHA-PA-007	1
22	Connecting Link - SCHA	AISI C1020 ZN PL	CVSSCHAPA003	2
23	Pivot - Series SCHA	AISI C1020 ZN PL	CVSSCHAPA001A	1
24	Cartridge Insert Check Valve	CS/Nitrile	CVSSCHA908029	1
25	O-Ring, Check Valve	Nitrile	Seal Kit	1*
26	Socket Head Screw	HXSC GR 8 ZN PL	Bolt Kit	4
27	SCHA Spring	SS 302	CVSSCHA908026	2
28	Plug - Series SCHA	AL 7075-T651	CVSSCHAPA004	2
29	O-Ring, End Plug	Nitrile	Seal Kit	2*
30	O-Ring, Body	Nitrile	Seal Kit	2*
31	Lever - CVS SCHA	D.I. 65-45-12 PL	CVSSCHAPA005	1
32	Lever Handle	ASTM A53-B ZN PL	CVSSCHA003	1
33	Wiper	Urethane	Seal Kit	1*
34	Rod Polypak	Urethane/Nitrile	Seal Kit	1*
35	Ram - Series SCHA	AISI C1045 CH PL	CVSSCHAPA002	1
36	Body - Series SCHA	AISI C1020 ZN PL	CVSSCHAPA001	1
37	Base - Series SCHA	AL 6061-T6	CVSSCHAPA006	1
38	90 Micron Sintered Filter Element	SS 316	CVS908025	1
39	O-Ring, Suction Port	Nitrile	Seal Kit	1*
40	SCHA Suction Port Spring	AL 7075-T651	CVSSCHA908023	1
41	1/2" SST Ball, Suction Port	SS 302	CVSA0053	1
	Seal Kit (O-Ring Kit) (Includes Keys 1,2,3,4,6,9,10,25, 29, 30, 33, 34, 39)		CVSSCHA Seal Kit	
	Bolt Kit (Includes Keys 8,15,18, 19, 20, 26)		CVSSCHA-B/N	

* Recommended Spare Part, Included in Seal Kit (CVS SCHA Seal Kit)

Figure 5: Self Contained Hydraulic Pump Assembly and Dimensions (in) – High Pressure

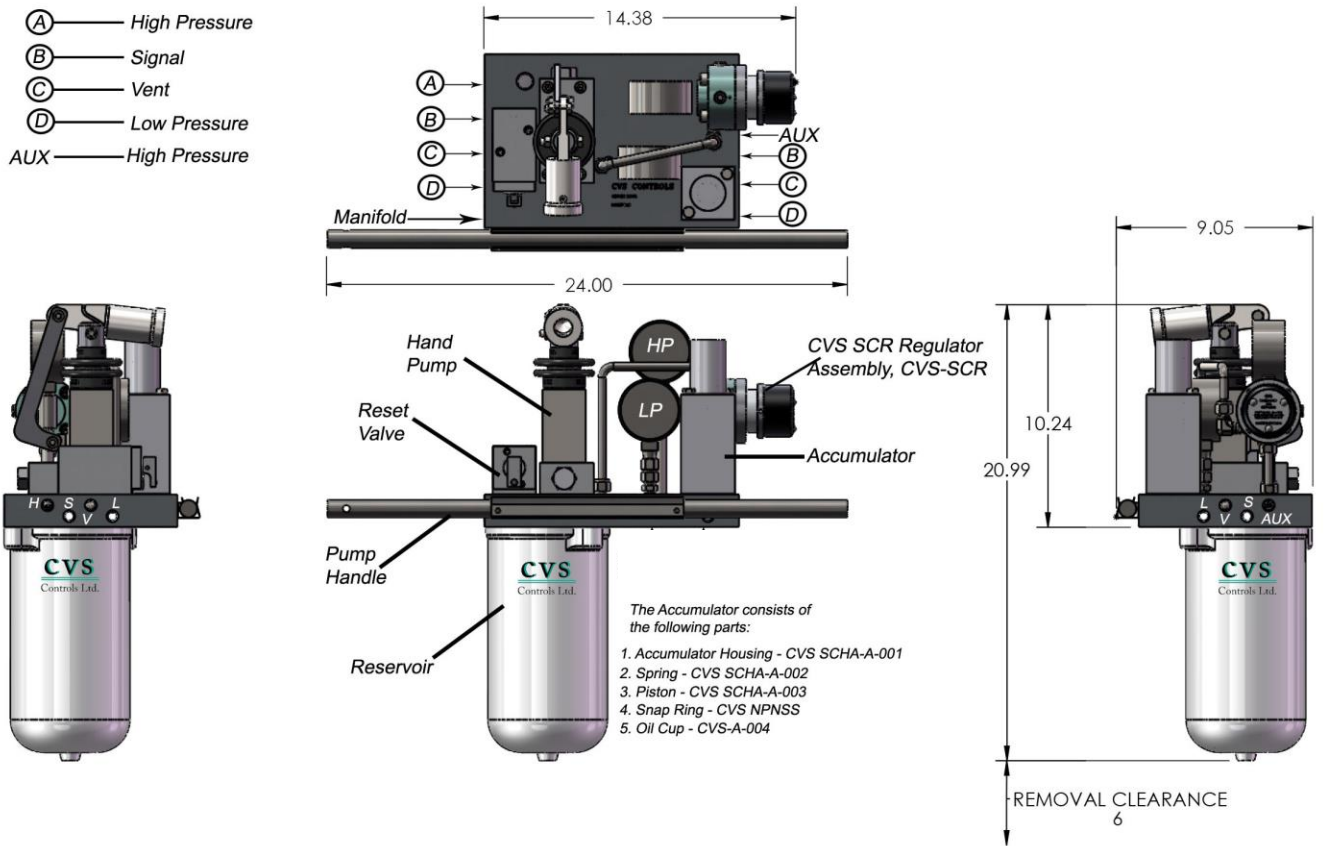
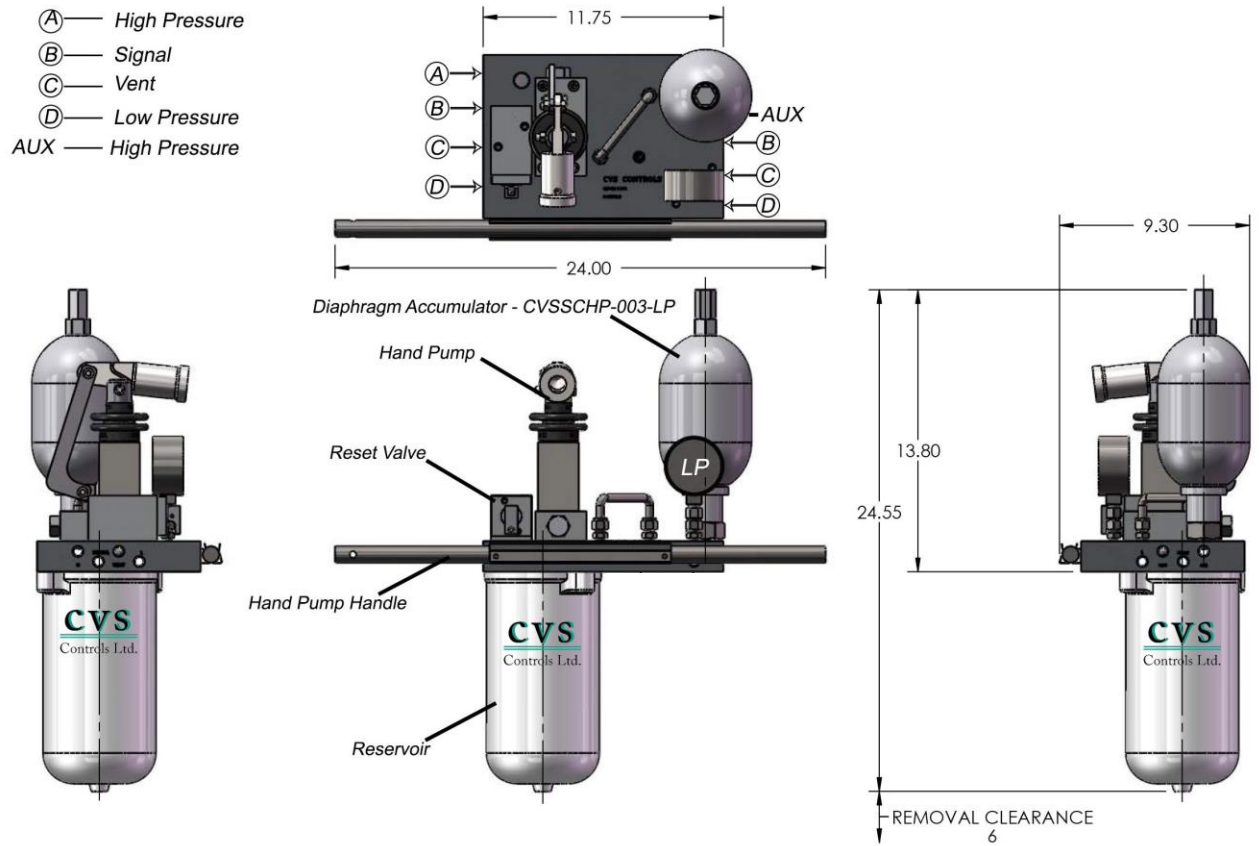

Figure 6: Self Contained Hydraulic Pump Assembly and Dimensions (in) – Low Pressure



CVS Self Contained Hydraulic Pump – Trouble Shooting

The following is trouble shooting tips for determining possible failures and leakages with SCHA pumps. Refer to page 9 for a labeled picture of an SCHA-HP Model, looking from the bottom side of the manifold with the reservoir removed for clarity.

1. Low pressure relief valve, set at 125PSI.

- If leaking, disassemble, clean, reassemble and set. If it continues to leak, replace.

2 Drain hole under manual latch.

- If oil is dripping, remove vent tubing line from manifold coming from shutdown devices.
- If dripping continues, remove manual latch, disassemble, clean, inspect o-rings for damage, replace if necessary and reassemble.
- If no leaking is present, then monitor the vent tubing line from shutdown devices for a possible failure.

3 – Fill hole for reservoir.

4 – Suction tube.

- If oil is continuously leaking down the tube, replace the check valve in the pump head assembly.
 - (Refer to the pump head assembly drawing)
 - Looking at front of pump, remove the hex plug (28) on back side of pump body.
 - Remove the spring (25).
 - Remove the check valve cartridge.
 - Install a new cartridge, ensure the flow arrow is in the correct direction.
 - Reinstall the spring and hex plug.

5 – Vent drain line.

- Use the same procedure as #2

6 – High pressure relief valve

- Set pressure is determined by the maximum pressure of the actuator.
- If leaking, disassemble, clean, reassemble and set.
- If it continues to leak, replace.

For more information, please contact a CVS Controls Sales Representative.

Self Contained Hydraulic Pump – Bottom Manifold Detail

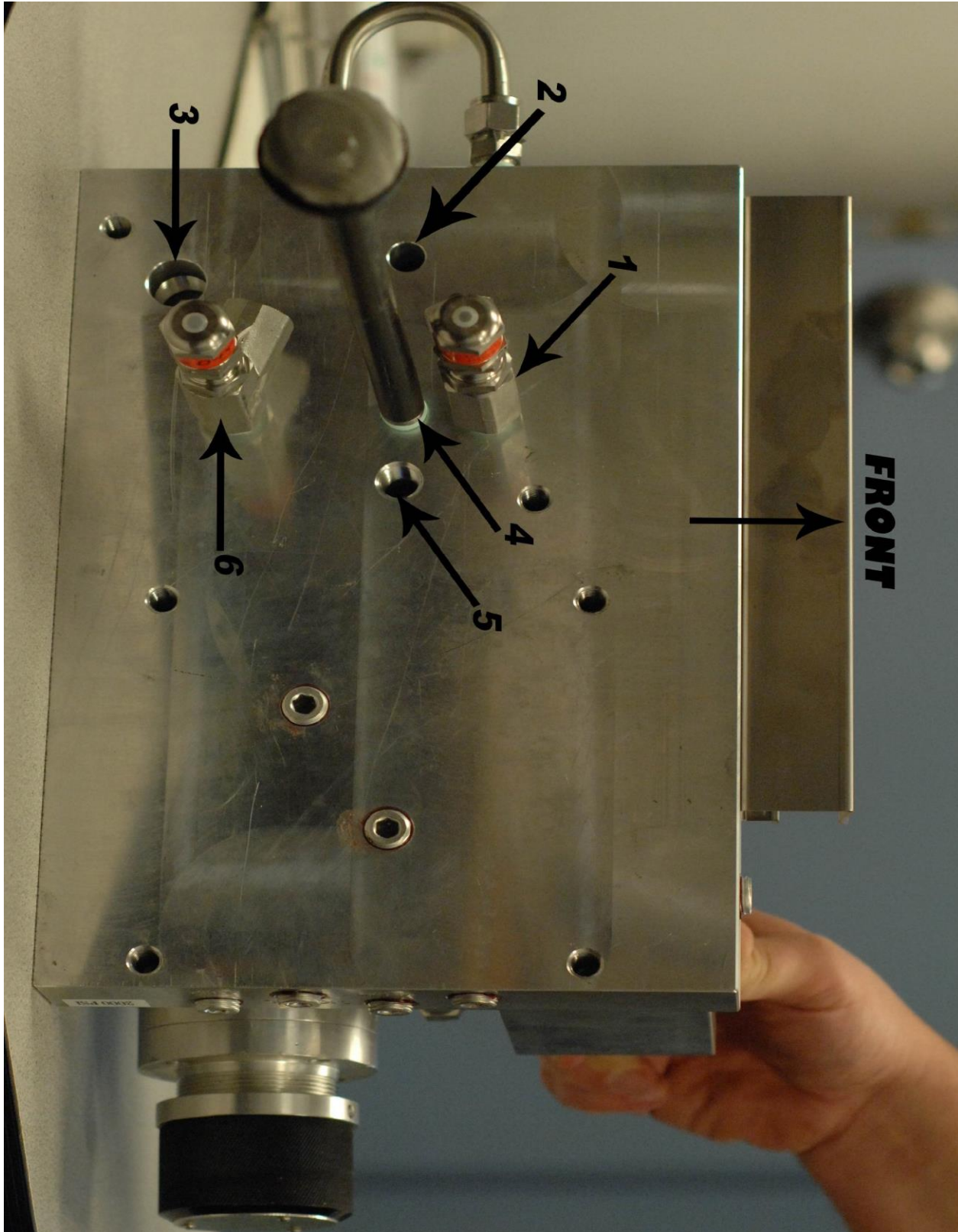

CVS SCR Regulator – Used in the CVS Self Contained Hydraulic Assembly, High Pressure

The CVS SCR Regulator is used for hydraulic oil service on our SCHA High Pressure Assembly.
1/4" NPT Inlet and Outlet
3000 PSI Max Inlet Pressure
Typical factory set point for the CVS SCR regulator is 80-90 psi

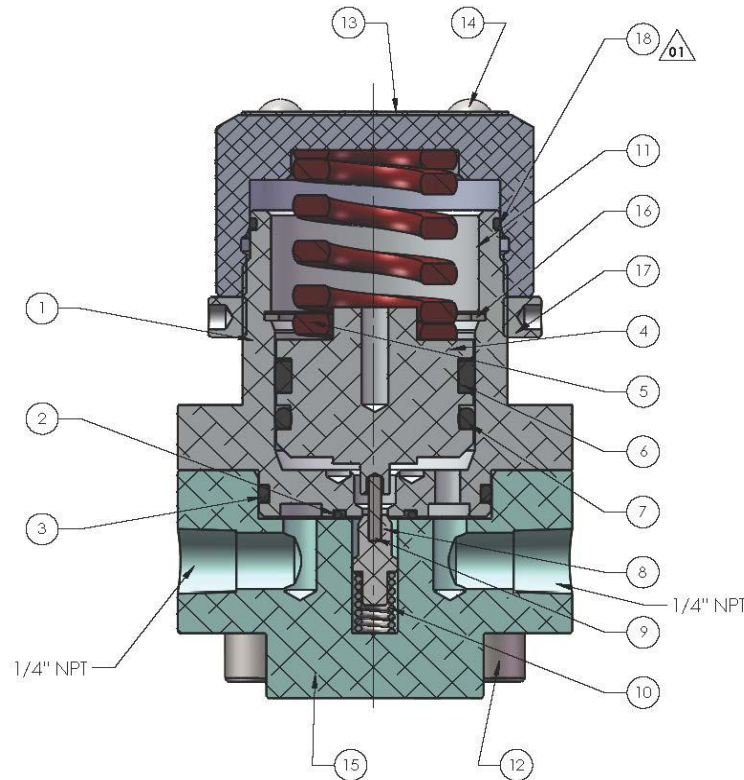

Item	Part Number	Description	Qty
1	CVS SCR-A-0001	Body	1
2*	CVS SCR-A-0002	O-Ring, Size 014	1
3*	CVS SCR-A-0003	O-Ring	1
4	CVS SCR-A-0004	Piston	1
5	CVS SCR-A-0005	Spring, Piston	1
6*	CVS SCR-A-0006	Seal, Piston	1
7*	CVS SCR-A-0007	O-Ring, Piston, Size 123	1
8**	CVS SCR-A-0008	Poppet	1
9**	CVS SCR-A-0009	Dowel Pin, Poppet	1
10	CVS SCR-A-0010	Spring	1
11	CVS SCR-A-0011	Cap	1
12	CVS SCR-A-0012	Cap Screw, 3/8-16x1.75	4
13	CVS SCR-A-0013	Name Plate	1
14	CVS SCR-A-0014	Rivet	3
15	CVS SCR-A-0015	Base	1
16	CVS SCR-A-0016	Retaining Ring, 1 9/16	1
17	CVS SCR-A-0017	Lock Nut, Cap	1
18	CVS SCR-A-0018	O-Ring, Size 031	
*Items included in CVS SCR Regulator Seal Kit, CVS-SCR-SealKit			
**Recommended Spare Items			

Self Contained Hydraulic Pump – Initial Filling and Start-Up Procedure

Upon receiving the CVS Controls Self Contained Hydraulic Pump, it may be required to initially be filled with supplied Hydraulic Fluid prior to operation.

This may be done one of two ways:

Option 1:

Prior to operation of the CVS SCHA it is required that the installed pipe plug be removed and replaced with supplied reservoir breather. Upon removing the pipe plug, a funnel may be used to fill reservoir with the supplied Hydraulic Fluid. (Figure 1).

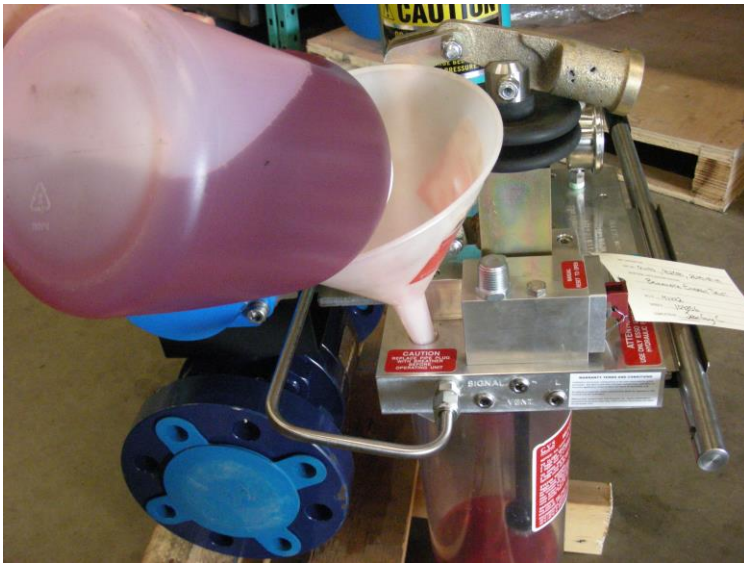

Figure 1

After filling reservoir, install supplied breather. (Figure2).

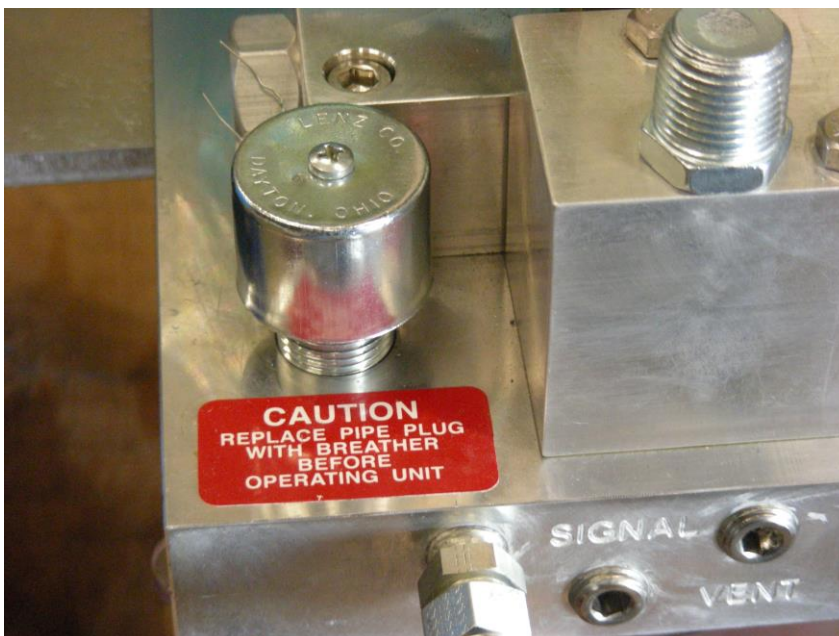

Figure 2

Self Contained Hydraulic Pump – Initial Filling and Start-Up Procedure – Continued

Option 2:

Filling the reservoir with supplied Hydraulic Fluid may also be done by first removing the reservoir. Remove two bolts securing the reservoir using a 14mm socket wrench or equivalent.

Fill the reservoir with supplied Hydraulic Fluid (Figure 3).



Figure 3

Replace reservoir, and secure using the two bolts, flat washers, and lock washers which were removed (Figure 4).



Figure 4

Install supplied breather (Figure 5).



Figure 5

The CVS Controls SCHA requires 3.6 Liters of Hydraulic Fluid. CVS Controls uses and supplies Esso Univis J13, unless an alternate is specifically requested.

Notes:

Notes:

CVS Controls Ltd. strives for the highest levels of quality and accuracy. The information included in this publication is presented for informational purposes only. CVS Controls Ltd. reserves the right to modify or change, and improve design, process, and specifications without written notice. Under no circumstance is the information contained to be interpreted to be a guarantee/warranty with regard to our products or services, applicability or use.

Selection, use and maintenance are the sole responsibility of the end user and purchaser. CVS Controls assumes no liability for the selection use and maintenance of any product.

CVS

CONTROLS

Head Office

3900 – 101 Street
Edmonton, Alberta, Canada
T6E 0A5
Office: (780) 437-3055
Fax: (780) 436-5461

Calgary Sales Office

3516 114 Avenue SE
Calgary, Alberta, Canada
T2Z 3V6
Office: (403) 250-1416
Fax: (403) 291-9487

Website: www.cvs-controls.com E-Mail: info@cvs-controls.com

April 2021