

# Instruction Manual

## CVS Series HPX and HPAX 2 through 6-Inch Globe Valves and 2-Inch Angle Valves

### Introduction

#### Contents

Contained in this manual are installation instructions, maintenance procedures and parts information for the 2 through 6-inch designs CVS HPX2D, HPX5T, HPAX2, HPAX5, Class 900 and 1500 ratings. 2 inch Class 2500 also included. Refer to the appropriate manuals for instructions for the accompanying actuator, positioner and additional accessories.

Trained or experienced personnel should carry out operation and installation of all pressure equipment. If you have any questions regarding the equipment, contact your CVS Controls representative.

#### Description

The CVS Series HP Control Valves are high pressure and angle valves, designed for high-pressure applications in the process control industry. They are equipped with metal seats, cage guiding and quick-change trim and push-down-to-close valve plug action. These valves use balanced valve plugs.



**Figure 1: CVS Series HPX Valve with Type 667 Actuator and CVS 2400 Smart Positioner**

In the CVS Series HPX2D and HPAX2, a piston ring provides the seal between the cage and the balanced valve plug. In the CVS Series HPX5T and HPAX5 that seal is provided by a pressure assisted seal ring.

CVS Series HPX Valves are available in the following body materials - LCC, WCB, WCC, WC9, C5, Monel, and CF8M SST.

Trim material is available in 316SST, 416SST, 17-4PH, Alloy6-Co.Cr-A, Cobalt and 316SST/Tungsten Carbide.

Additional materials may be available upon request. Please contact a CVS Controls representative for more information

Head Office  
3900 - 101 Street  
Edmonton, Alberta, Canada T6E 0A5  
Office: (780) 437-3055  
Fax: (780) 436-5461

**CVS**  
**Controls Ltd.**

Calgary Sales Office  
205, 2323 - 32 Avenue NE  
Calgary, Alberta, Canada T2E 6Z3  
Office: (403) 250-1416  
Fax: (403) 291-9487

Website: [www.cvs-controls.com](http://www.cvs-controls.com) E-Mail: [info@cvs-controls.com](mailto:info@cvs-controls.com)

**Table 1: Specifications**

Specification	Description
End Connection Style	All CVS Series Design HPX Control Valves are available in 3, 4 and 6-inch sizes, Class 900 and 1500. 2 inch available in Class 900, 1500, and 2500.
	Design HPAX configuration is available in a 2-inch valve, class 900 and 1500
WCB and LCC Cast Steel Valves	Flanged Ends: RF (raised face) and RTJ (ring type joint)
CF3M (316 L SS) Valves	Flanged Ends: RF (raised face) and RTJ (ring type joint)
Maximum Inlet Temperature and Pressure	Flanged: Consistent with Class 900, 1500 and 2500 in accordance with ASME B16.34 1996
Shutoff Classification	See Table 2
Flow Characteristic	Standard Cage: equal percent, modified equal percent, or linear
Flow Direction	Standard Cage: Normally Flow Down
Approximate Shipping Weight	See Table 3 for Valve Body and Bonnet Assemblies
Notes:	
1. Consult your CVS Controls representative for end connections and DIN ratings.	
2. Class 900 and 1500 valves are identical for 2-inch valves. Class 900 and 1500 valves for sizes 3, 4 and 6-inch are not identical.	
3. The centerline-to-face dimension does not conform to ANSI/ISA S75.12.	
4. The Temperature and Pressure rating in this manual and any applicable standard should not be exceeded.	

## Installation

Exceeding the recommended pressure and temperature limits from Table 1, or those indicated on the nameplates of your CVS Controls valve, can result in personal injury and property damage. CVS Controls recommends the installation of a relief valve to protect against overpressure situations.

CVS Series HPX900 and 1500, HPX2D and HPX5T are designed to meet specific conditions for fluid control, temperature, pressure and pressure drop. The limiting factor on these valves can be the body/trim material combinations. Do not install these valves in any other applications without first consulting with your CVS Controls representative.

1. Inspect the valves for shipping damage and foreign debris while uncrating.
2. Ensure the pipeline is free of welding slag, chips and other debris by blowing out the line before installation.

3. Position the valve on the line so the flow direction indicator corresponds to the direction of the flow of the pipeline.
4. CVS Controls recommends the installation of a standard three-valve maintenance bypass. This will allow isolation of the control valve without shutting down the pipeline system.
5. Install approved gaskets between the valve body and the pipeline flanges.
6. If the actuator has been shipped separately, refer to the mounting procedure in the applicable instruction manual.
7. If the valve body arrives without packing installed in the packing box, it will be necessary to install the packing before putting the valve into service. To complete these procedures, follow the instructions under "packing maintenance" in this manual.
8. **Note:** It may be necessary to adjust the packing to prevent leakage. Prior to shipping the packing was tightened, and may require some adjustment for specific conditions.

**Table 2: Shutoff Classifications per ANSI/FCI 70-2-1991**

Valve Design	Port Diameter Inches (mm)	ANSI Leakage Class
HPX2D	1-7/8 (47.6) and smaller	II
	2-5/16 (58.7) to 3-5/8 (92.1)	II-Standard
HPAX5T	All	V-Standard

**Table 3: Approximate Shipping Weights: Valve and Bonnet Assembly**

Valve Type	Valve Size (Inches)	Class	Pounds Flanged	Kilograms Flanged
Globe Valve	2	900 & 1500	158	72
	2	2500	229	104
	3	900	276	125
		1500	284	129
	4	900	507	230
		1500	548	249
	6	900	1127	511
		1500	1228	557
Angle Valve	2	900 & 1500	153	69

## Maintenance

Internal valve components are subject to normal deterioration and must be inspected and replaced as required. The necessity of inspections and replacement of parts will depend on the severity of service conditions. Inspections and maintenance must be carried out on a regularly scheduled basis.

To ensure the safety of personnel and to protect against property damage, the following steps should be carried out before beginning disassembly.

1. To prevent the valve from opening suddenly, disconnect any operating lines to the actuator. This would include air pressure, electrical power or control signal lines.
2. Isolate the valve by using the bypass valve or by shutting down the process completely. Relieve the pressure and drain the process fluid from both sides of the valve.
3. Relieve the pressure contained in the actuator by venting the actuator loading pressure and relieving any power actuator spring compression.
4. Lock-out procedures should be strictly adhered to while the equipment is being serviced.
5. The CVS HPX Designs use spiral-wound gaskets that are compressed to provide their seal. Spiral-wound gaskets are designed for single service, and if they are disturbed they must be replaced upon reassembly. Used spiral-wound will not seal properly within the assembly.

**Table 4: Torque for Body-To-Bonnet Bolting (using Nickel Never Seez Lubricant)**

Valve Rating	Valve Size, Inches	Torque			
		Lbf•ft		N•m	
		B7, B16, BD and 660 Studs	B8 and B8M Studs	B7, B16, BD and 660 Studs	B8 and B8M Studs
Class 900 and 1500	2	290	180	390	240
	3	540	390	730	530
	4	720	540	970	730
	6	1250	950	1700	1300
Class 2500	2	540	390	730	530

## Packing Lubrication

These instructions are for the lubricator or lubricator isolating valve (Figure 2). If the lubricator or lubricator isolating valve have been installed, they will be in place of the pipe plug (key 16, Figures 4 and 6) and are designed for packing that requires lubrication, including PTFE/composition. CVS Controls recommends a silicon-based lubricant. Lubricant is not recommended for oxygen services or for processes that operate in excess of 500F. To add lubricant to the packing box, turn the capscrew in a clockwise direction.

### For Lubricator/Isolating Valve

1. Open the isolating valve.
2. Turn the capscrew in a clockwise direction.
3. Close the isolating valve.

## Packing Leakage

### Spring-Loaded PTFE V-ring packing

To eliminate leakage, tighten the packing flange nuts (key 2, Figures 4 and 6). If leakage cannot be controlled in this manner, the packing will need to be replaced.

### Other Packing

If packing other than Spring-Loaded PTFE V-ring has been used, attempt to eliminate the leaking and create a stem seal by tightening the packing flange nuts to the minimum recommended torque given in Table 5. If leakage continues, the packing will need to be replaced.

**Figure 2: Lubricator and Lubricator/Isolating Valve**

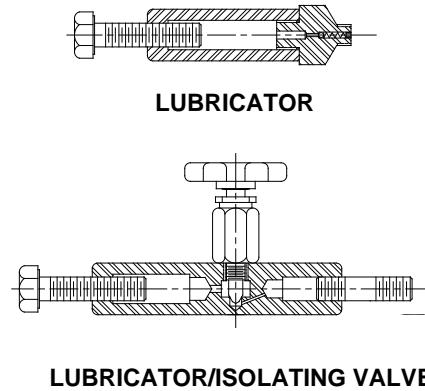

### New Packing

If tightening the appropriate flange nuts does not solve the leakage problem and the packing is relatively new, leakage could indicate damage to the packing box wall or to the stem. Inspect the valve plug stem for a good surface finish as well as the packing box wall for nicks and scratches that could compromise the seal.

### Hint:

If leakage originates from the outside diameter of the packing, check the packing box wall for nicks or scratches. If leakages originates from the inside diameter of packing, check the stem for nicks or scratches.

**Table 5: Recommended Torque for Packing Flange Nuts (non live-loaded)**

Stem Diameter		Valve Body Rating	Torque			
Inches	mm		Lbf•ft		N•m	
			Min	Max	Min	Max
1/2	12.7	900	9	13	12	18
1/2	12.7	1500	11	16	15	22
1/2	12.7	2500	13	18	18	24
3/4	19.1	900	20	30	27	41
3/4	19.1	1500	25	37	34	50
3/4	19.1	2500	30	45	41	61

**Figure 3: CVS Series HPX and HPAX Packing Arrangements**

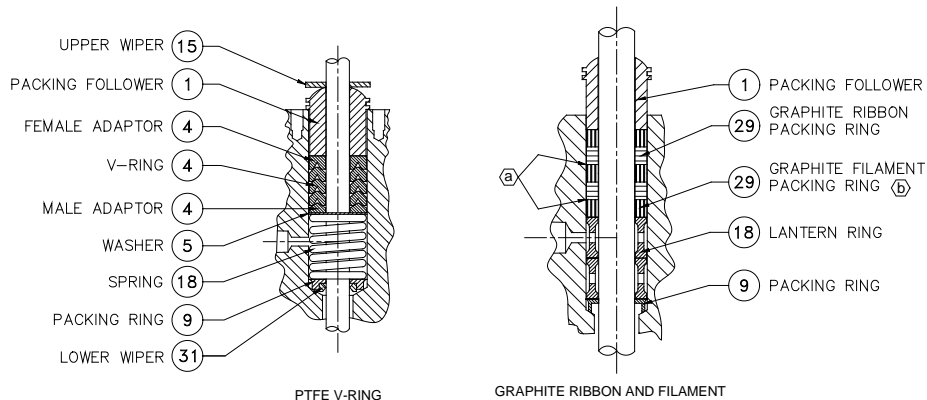

**SINGLE PACKING**

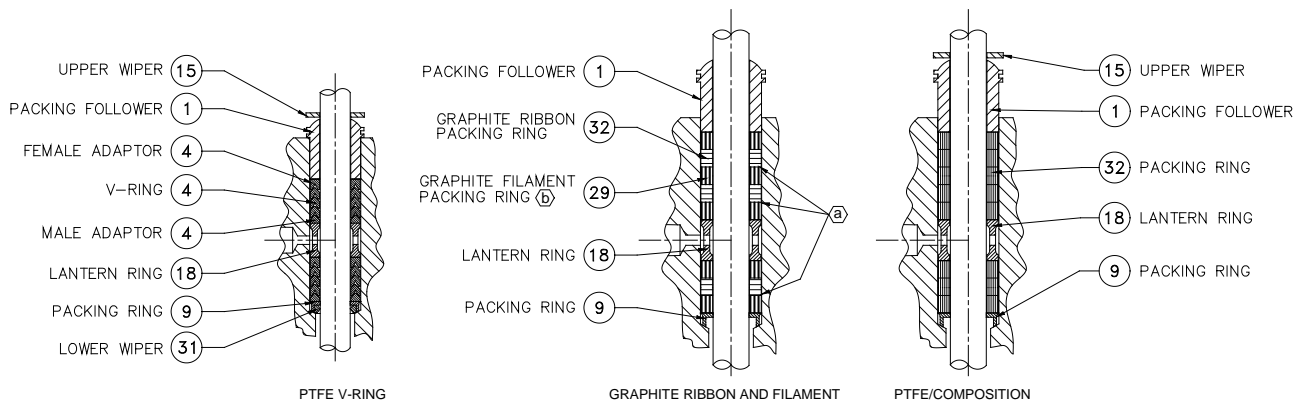

**DOUBLE PACKING**

**NOTES:**

- Ⓐ ZINC WASHER, ONE USED BELOW EACH GRAPHITE RIBBON RING.
- Ⓑ HAS THE APPEARANCE OF A WOVEN OR BRAIDED RING.

**Replacing Packing**

Prior to beginning any maintenance, it is important to isolate the valve from the line pressure, and to release all pressure from the valve body. Disconnect all operating lines to the actuator, including air pressure, electrical power or control signal lines. The process pressure should be released both upstream and downstream of the valve. Drain the process fluid from both sides of the valve.

Employ lock-out procedures to ensure the safety of personnel and equipment during valve service.

**Note: Extreme caution must be used during disassembly. Nicks and scratches will affect the ability to seal the valve in the future.**

1. Remove the cap screws in the stem connector and separate the two halves.
2. Exhaust any actuator pressure and disconnect the actuator supply line and any leakoff piping.
3. Remove the actuator from the bonnet (key 6) by removing the yoke lock nut (key 15) and then remove the actuator from the bonnet.

4. Back off the packing flange nuts (key 2) until the packing is free of constriction against the valve plug stem (key 20). Remove any additional equipment from the valve plug stem threads, including the travel indicator disk and stem locknuts.
5. When removing the bonnet ensure the valve plug and stem assembly (keys 20 and 22) remain off the seat ring (key 23). This will prevent damage to the seating surfaces as a consequence of the assembly falling from the bonnet after being partially raised.
6. Apply caution to avoid damage to the gasket seating surface.
7. **Caution** must be used when handling the HPXd and HPAX2 piston rings. These rings are brittle and in two pieces.
8. Remove the bonnet in the following steps. Do not remove a jammed bonnet with equipment that can store energy. Sudden release of the bonnet can result in unexpected and potentially dangerous movement. If the cage becomes jammed it is important to provide support for the cage. This will prevent the cage from falling unexpectedly.
9. Loosen the bonnet hex nuts (key 8) which attach the bonnet to the valve, by approximately 1/8 of an inch (3mm).
10. Pry between the bonnet (key 6) and valve body (key 21) to loosen the body to bonnet gasket joint. Continue prying around the bonnet until the bonnet loosens. If no fluid is released from the joint, unscrew the bonnet nuts (key 28) completely.
11. Carefully remove the bonnet and valve plug assembly (key 6, 20, 22) as a unit. Ensure that the valve plug and stem assembly (keys 20 and 22) remains on the seat ring (key 23) and avoid nicking or scratching the gasket sealing surface.
12. To remove the bonnet from the valve stem remove the bonnet hex nuts (key 8). Carefully lift the bonnet off the valve stem. In the event that the valve plug and stem assembly become detached they can be tapped back down with a lead or brass hammer. Place the bonnet on a suitable surface such as wood or cardboard to protect it from damage.
13. Remove parts in this order:
  - 13.1. Valve Plug Assembly (key 20, 22)
  - 13.2. Bonnet Gasket (key 19)
  - 13.3. Cage (key 12)
  - 13.4. Seat Ring (key 23)
  - 13.5. Seat Ring Gasket (key 24)
14. Clean all gasket surfaces with a wire brush, following the direction of the serrations.
15. Cover the valve body openings to protect the gasket surfaces.
16. Unscrew the packing flange nuts (key 2)
17. Remove the following from the bonnet:
  - 17.1. Packing flange (key 3)
  - 17.2. Upper wiper (key 13)
  - 17.3. Packing follower (key 14)
18. Push the remaining packing parts from the valve side of the bonnet. This can be done with a rounded rod or any other tool that will not cause damage or scratch the packing wall.
19. Clean the packing box and the following metal components: spring or lantern ring, packing box ring, packing follower and, if required, the v-ring packing washer. Finish all required maintenance.
20. Examine the valve stem threads for sharp edges that may damage the new packing. Emery cloth or a whetstone can be used to smooth out any sharp edges or burrs.
21. Remove the protective covering from the valve body. Using a new seat ring gasket (key 24) and bonnet gasket (key 19), install the seat ring (key 23) and cage (key 12).
22. Install the stem and plug assembly (key, 20, 22). Slip the bonnet (key 6) over the stem and line it up with the studs.
23. Replace the packing hex nuts (key 2)
  - 23.1. For pre-lubricated hex nuts (identified by the black film coating on the nut threads) tighten the hex nuts finger tight.
  - 23.2. For all other nuts, CVS Controls recommends that you lubricate the stud threads with Never Seez Pure Nickel special lubricant or equivalent. Tighten the hex nuts finger tight.
24. To centre the trim, the valve will need to be stroked several times. Using proper bolting procedures tighten the nuts to no more than 1/4 of the torque values specified in Table 4.

25. Increase the torque on each nut by an additional 1/4 of the torque value using the standard crisscross pattern. Repeat this pattern until the torque values in Table 4 have been reached. Apply the final torque value again and if any bolts turn, all of the bolts will require retightening.
26. Using the appropriate arrangement from Table 3, install new packing and metal packing box parts. It may be necessary to pre-lubricate packing parts with silicone-based grease.
27. Using a smooth-edged pipe, cautiously tamp each soft packing part into the packing box. To prevent trapping air between the rings, add one ring at a time without forcing them below entrance chamber of the packing box. With each additional ring the stack should only be pushed down the thickness of one ring.
28. Install:
  - 28.1. Packing Follower (key 14)
  - 28.2. Wiper (key 13)
  - 28.3. Packing Flange (key 3)
29. Lubricate both the packing flange studs (key 1) and the faces of the packing flange nuts (key 2). Finger tighten the packing flange nuts.
30. For packing type:
  - 30.1. Spring-loaded PTFE V-Ring (Figure 3): tighten the packing flange nuts until there are no leaks.
  - 30.2. Graphite: initially tighten the packing flange nuts to the maximum torque value in Table 5. Release the packing flange nuts and retighten them to the maximum torque value given in Table 5.
  - 30.3. Other packing types: tighten the packing flange nuts in small increments alternately. Repeat the process until one of the nuts reaches the maximum torque value from Table 5. Now continue tightening the flange nuts until the packing flange is level and at right angles (90 degrees) to the valve stem.

**Table 7: Valve Stem Connection Torque and Drill Size for Groove Pin Hole**

Valve Size Inches	Valve Stem Diameter		Valve Design	Valve Stem Connection		Drill Size for Groove Pin Inches
	Inches	mm		Lb•ft	N•m	
2	1/2	12.7	HPX2D, HPAX2 HPX5T, HPAX5	60-85	81-115	1/8
	3/4	19.1		175-250	237-339	1/8
3	1/2	12.7	HPX2D, HPX5T	60-85	81-115	1/8
	3/4	19.1		175-250	237-339	3/16
	1	25.4		310-355	420-481	1/4
4	3/4	19.1	HPX2D, HPX5T	175-250	237-339	3/16
	1	25.4		310-355	420-481	1/4
6	3/4	19.1	HPX2D, HPX5T	175-250	237-339	3/16
	1	25.4		310-355	420-481	1/4
	1-1/4	31.8		610-670	827-908	1/4

### Trim Removal

1. Remove the actuator and the bonnet. Refer to steps 1-4 in replacing packing.
2. Remove the valve plug and stem assembly (key 20, 22). If the assembly is to be reused protect the valve stem and plug seating surface from nicks and scratches by taping them.
3. Remove:
  - 3.1. Cage (key 12)
  - 3.2. Bonnet Gasket (key 19)
  - 3.3. Seat Ring (key 23)
  - 3.4. Seat Ring Gasket (key 24)
4. Follow the steps in the valve plug maintenance procedure to complete the remaining steps for trim removal.

---

## Valve Plug Maintenance

---

1. Remove the valve plug and stem assembly (key 20, 22) using the trim removal procedures.
2. Follow the instructions for your specific equipment:
  - 2.1. For HPX2D and HPAX2 valves, remove both halves of the piston rings (key 11) from the grooves in the valve plug.
  - 2.2. For HPX5T and HPAX5 valves, pry the retaining ring (key 27) off the valve plug with a screwdriver. Gently slide the backup ring (key 28) and seal ring (key 29) of the valve plug.
3. For replacement of the valve plug stem drive out the groove pin from the valve plug and unscrew the stem.
4. **Note:** When replacing a valve plug always replace the corresponding valve plug stem. The stem and pin should be ordered as an assembly.
5. Screw the stem (key 20) into the valve plug (key 22), tightening the stem to the recommended torque given in Table 7. Determine the correct drill size (Table 7) and drill through the stem using the groove pinhole as a guide.
6. To lock the assembly, drive in the groove pin (key 10).
7. If required, lap the seating surfaces prior to installing the piston rings or seat ring. Use the trim replacement instructions for the piston ring and seat ring installation and reassembly of the valve.
3. The CVS Controls Series HP designs have spiral gaskets, which are compressed to provide their seal. Spiral-wound gaskets are designed for single service. If they are ever disturbed they will need to be replaced on reassembly. *The previously used gasket may be used to lap the seat but the gasket must be replaced with a new gasket.*
4. Using the instructions under trim replacement, install "old" seat ring gasket, seat ring, cage and the "old" bonnet gasket.
5. Install the valve plug and stem assembly without piston rings or seal ring into the cage.
6. Slip the bonnet over the valve stem. Fasten the bonnet by securing four of the hex nuts.
7. It will be necessary to attach a handle to the valve stem. This could be a piece of strap metal attached by stem locknuts.
8. Turn the handle alternately in both directions thereby lapping the seat, taking care not to gull the seat and plug.
9. When complete, disassemble stopping to mark the positions of the cage with a soft-tipped marker.
10. Clean the seating surfaces, replace the gaskets and reassemble. Test for leakage and repeat the lapping procedure if required.
11. The position of the seat ring and cage must remain constant to preserve the effects of lapping. Ensure that when parts are removed for maintenance and cleaning, they are returned to their original position.

---

## Seat Lapping

---

With metal-to-metal seating in any valve, a small amount of leaking can be expected. If the leakage becomes excessive it is possible to limit the valve leakage by seat lapping.

1. Eliminate any deep nicks through machining rather than grinding.
2. Apply a good quality lapping compound mixture of 280 to 600-grit to the bottom of the valve plug.

---

## Trim Replacement

---

Complete all necessary maintenance on the trim including cleaning all gasket surfaces. Inspect sealing surfaces. Nicks and scratches will prevent the gasket from sealing properly.

1. Replace:
  - 1.1. Seat Ring Gasket (key 24)
  - 1.2. Seat Ring (key 23)
  - 1.3. Cage (key 12)
  - 1.4. Piston Rings (key 11)
  - 1.5. Seal Rings (key 29)

**2. For CVS HPX2D and HPAX2 designs:**

- 2.1. New piston rings will be delivered in one piece. The piston ring can be broken in half by scoring and breaking over a hard surface such as a table edge. The other recommended method is to break the ring with the use of a smooth or taped jawed vise. Install the new ring in the vise and apply pressure until the ring becomes an oval. Continue applying pressure until the ring snaps on both sides. If just one side snaps do not try to rip off the other side. Apply pressure until the second side breaks.
- 2.2. Remove the protective covering from the valve plug and stem assembly.
- 2.3. Insert the piston rings into the piston ring grooves matching the broken ends.

**3. For HPX5T and HPAX5 designs:**

- 3.1. Install for flow-down applications (see Figure 5, view A), install the ring with the open side facing the seat ring end of the valve plug.
- 3.2. Install the back-up ring (key 28) on the valve plug (key 22) and secure with the retaining ring (key 27).
4. Install the valve plug (key 22) in the cage (key 12) and place the bonnet gasket (key 19) on the cage.
5. After lubricating the bonnet stud threads (key 7) and the faces of the bonnet hex nuts (key 8), tighten the hex nuts finger tight.

**Note:** If pre-lubricated hex nuts are used, lubrication will not be necessary. CVS Controls recommends Never-Seez Pure Nickel special lubricant or equivalent for lubricating.

6. Tighten the bolts in a three-step process:
  - 6.1. Begin by tightening the bolts to 1/4 of the specified normal torque (Table 4) using the standard crisscross bolting pattern.
  - 6.2. Using the same method tighten the bolts to an additional 1/4 of the specified normal torque value (Table 4)
  - 6.3. Continue tightening bolts to the nominal torque value from Table 4.
7. Test the nuts by applying the final torque value. If the nuts still rotate, tighten all the nuts again.
8. Install the packing and the packing box components following the instructions from "Replacing Packing".
9. Using the actuator instructions mount the actuator.
10. If leakage occurs in the packing when the valve is put back into service, it may be necessary to retighten the packing flange nuts.

## Parts Ordering

Every CVS Controls Series HPX and HPAX valve is identified by a serial number, located on the valve body. Please quote this number when communicating with CVS Controls regarding your valve.

# CVS Series HPX Valves

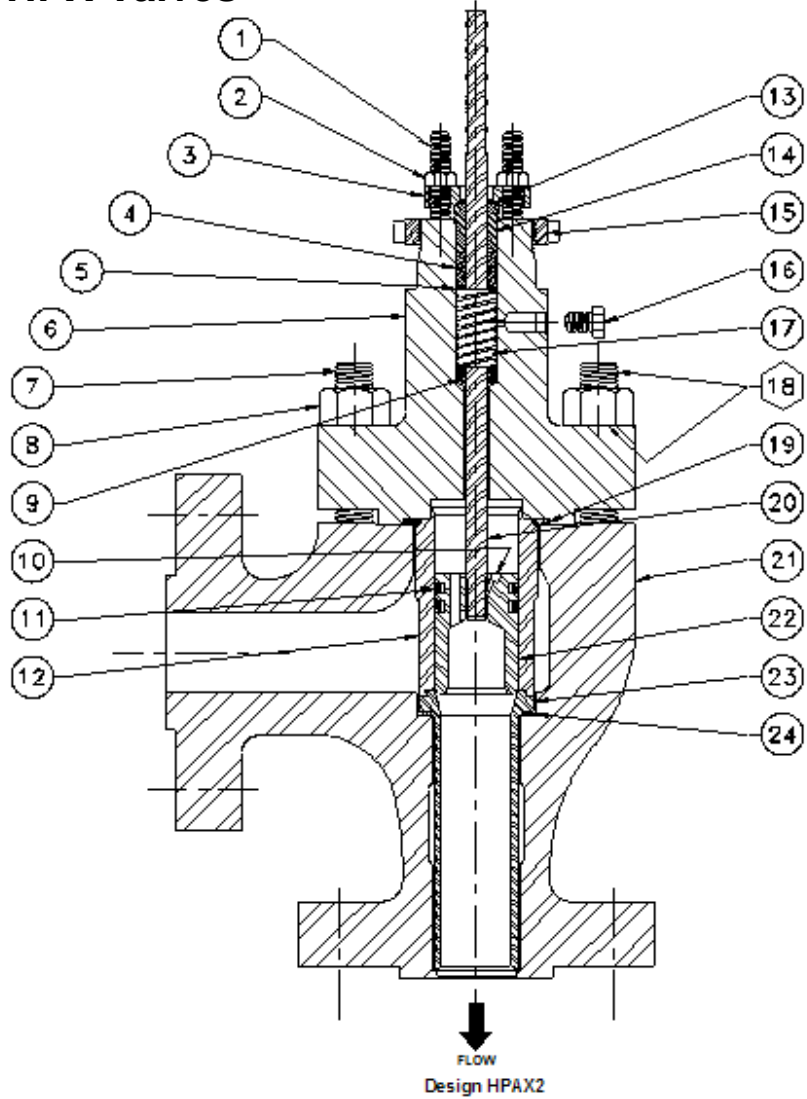

Figure 4 - 2" HPAX2 Valve

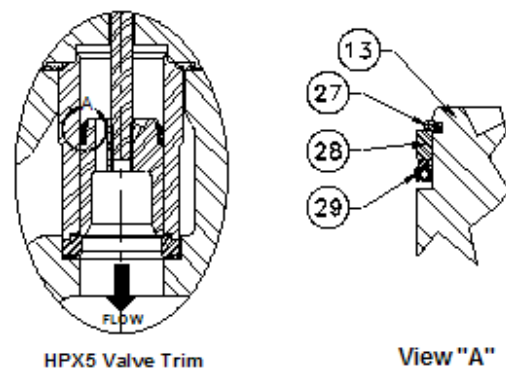

Figure 5 - Design HPX5 Trim

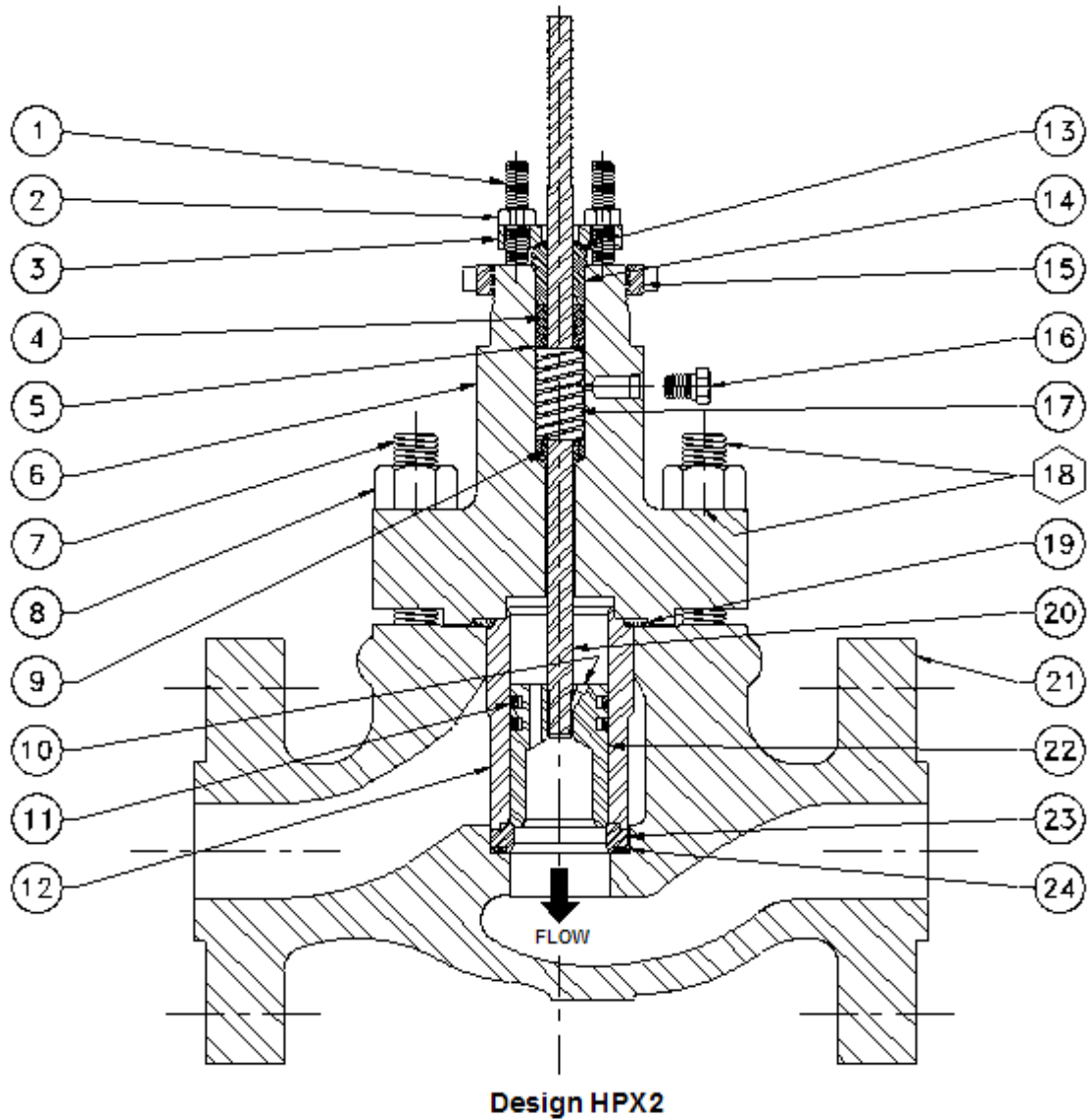

Figure 6 - 2" HPX2 Valve

### Parts Reference

Key	Description	Key	Description	Key	Description
1	Packing Flange Stud	11	Piston Ring	21	Valve Body
2	Packing Flange Nut	12	Cage	22	Valve Plug
3	Packing Flange	13	Upper Wiper Felt	23	Seat Ring
4	Packing Set (TFE or Graphoil)	14	Packing Follower	24	Seat Ring Gasket
5	Packing Washer	15	Yoke Lock Nut	25	Drive Screw
6	Bonnet	16	Pipe Plug	26	Flow Arrow
7	Bonnet Stud	17	Spring/Lantern Ring	27	Retaining Ring
8	Bonnet Hex Nut	18	Lubricant	28	Back Up Ring
9	Lower Wiper	19	Bonnet Gasket	29	Seal Ring
10	Groove Pin	20	Valve Stem		

# CVS Series HPX and HPAX Valves

## Parts List

Key	Description	Stem Size	Part Numbers	Key	Description	Stem Size	Part Numbers	
1	Packing Flange Stud	1/2"	CVS1E9444X0212	19*	Bonnet Gasket	N/A	See Tables	
		3/4"	CVS1E9449X0162					
2	Packing Flange Nut	1/2"	CVS1E944335252	20*	Valve Stem	N/A	See Tables	
		3/4"	CVS1E944635252					
3	Packing Flange	1/2"	CVS 1E944223072	21* <sup>C</sup>	Valve Body	N/A	Contact CVS Controls	
		3/4"	CVS1E944823072					
4*	TFE Packing Set	1/2"	CVS1R290201012	22	Valve Plug	N/A	See Following Tables	
		3/4"	CVS1R290401212					
	Graphol Packing Set	1/2"	CVS1V3802X0022					
		3/4"	CVS1V2396X0022					
5	Packing Washer	1/2"	CVS1F125136042	23*	Seat Ring	N/A	See Tables	
		3/4"	CVS1F125036042					
6 <sup>A</sup>	Bonnet	N/A	Contact CVS Controls	24*	Seat Ring Gasket	N/A	See Tables	
7	Bonnet Stud	N/A	Contact CVS Controls	25 <sup>D</sup>	Drive Screw	N/A	-----	
8	Bonnet Hex Nut	N/A	Contact CVS Controls	26 <sup>D</sup>	Flow Arrow	N/A	-----	
9*	Lower Wiper	1/2"	CVS1J872206332	27 <sup>D</sup>	Ret. Ring 1-7/8" Port e	N/A	CVS10A4330X012	
		3/4"	CVS1J872306332				CVS10A4219X012	
10*	Groove Pin	1/2"	-----				Ret. Ring 1-7/8" Port e	CVS16A5484X012
		3/4"	-----				Ret. Ring 3-5/8" Port e	CVS10A4225X012
11*	Piston Ring	N/A	See Tables				Ret. Ring 4-5/8" Port e	CVS10A5410X012
12*	Cage	N/A	See Tables				Ret. Ring 5-3/8" Port e	
13*	Upper Wiper Felt	1/2"	CVS1J872706332	28* <sup>D</sup>	Back Up Ring	1/2"	See Tables	
		3/4"	CVS1J872806332			3/4"		
14	Packing Follower	1/2"	CVS1E944335072	29* <sup>D</sup>	Seal Ring	1/2"	See Tables	
		3/4"	CVS1E944735072			3/4"		
15*	Yoke Lock Nut	1/2"	CVS1E807423062	A-If required as a replacement, specify valve size, stem diameter, serial number and desired material B-Never Seez Nickel Special C-If required as a replacement, specify valve size, stem, diameter, serial number and desired material D-Not Shown *-Recommended Spare Parts				
		3/4"	CVS1E832723062					
16	Pipe Plug	1/2"	CVS1A767535072					
		3/4"	CVS1A767535072					
17	Spring /Lantern Ring	1/2"	CVS1F125537012					
		3/4"	CVS1F125637012					
18 <sup>D</sup>	Lubricant	N/A	-----					

### Key 11: Graphite Piston Ring for CVS Series HPX2D (2 to 4-inch) and HPAX2 (2-inch only)

Valve Size Inches	Quantity	Port Diameter		Class 1500	
		Inches	mm	-425°F to 800°F (253°C to 426°C)	801°F to 1000°F (427°C to 537°C)
2	2	1-7/8	47.6	CVS1U2216X0012	CVS1U2216X0022
3	2	2-7/8	73.0	CVS1U2300X0012	CVS1U2300X0022
4	2	2-7/8	73.0	CVS1U2300X0012	CVS1U2300X0022
	2	3-5/8	92.1	CVS16A5482X012	CVS16A5482X022
6	4	4-3/8	111.1	CVS1U2392X0012	CVS1U2392X0022
	3	5-3/8	136.5	CVS11A9727X022	CVS11A9727X032

### Key 29: Seal Ring for CVS Series HPX5T (2 to 6-inch) and HPAX5 (2-inch only)

Valve Size Inches	Port Diameter		Key 11 Seal Ring Valve Body Rating Class 1500
	Inches	mm	
2	1-7/8	47.6	CVS10A4216X012
3	2-7/8	73.0	CVS10A4215X012
	2-7/8	73.0	CVS10A4215X012
4	3-5/8	92.1	CVS16A5485X012
	4-3/8	111.1	CVS10A4223X012
6	5-3/8	136.5	CVS10A5411X022

## Key 20: Valve Stem for Class 1500

Valve Size, NPS	Yoke Boss Inches	Valve Stem Connection		Valve Stem Travel		Description	Material	
							316 SST Standard Bonnet	316SST Extension Bonnet
		Inches	mm	Inches	mm			
1	2-13/16 And 3-9/16	1/2	12.7	0.75	19.1	M-Form or M-Flute w/0.25" (6.4mm) port	CVS1N821035162	CVS10A8840X512
				0.75	19.1	M-Flute w/0.375" or 0.5" (9.5 or 12.7mm)port	CVS1N821035162	CVS10A8840X512
				0.75, 1.125	19.1, 29	M-Form w/0.5", 0.75" or 1" (12.7, 19.1, 25.4mm)port	CVS10A8840XB42	CVS1P669435162
		3/4	19.1	0.75, 1.125	19.1, 29	M-Form w/0.75" or 1" (19.1, 25.4mm)port	CVS1K5878X0012	CVS1L384135162
				0.75, 1.125	19.1, 29	HPAXS with 0.75" (19.1mm)port	CVS16A4704X322	CVS16A4704X532
		2	2-13/16 And 3-9/16	1/2	12.7	0.75, 1.125, 1.5	19.1, 29, 38	M-Form, M-Flute HPX, HPAX, HPX5T, HPAX5, HPXS, HPAXS
0.75, 1.125, 1.5	19.1, 29, 38					M-Form HPX, HPAX, HPX5T, HPAX5	CVS1P6696X0012	CVS1P669735162
3/4	19.1			0.75, 1.125	19.1, 29	HPAXS w/0.75"(19.1mm) port	CVS16A4704X042	CVS16A4704X492
				0.75, 1.125	19.1, 29	HPAXS w/1" (25.4mm)port	CVS16A4704X322	CVS16A4704X512
2	5	1	25.4	0.75	19	M-Form w/1" (25.4mm)port	CVS10A3282X012	CVS11A3429X152
						M-Form w/1.25" (31.8mm)port	CVS10A3282X012	CVS11A3429X152
						HPAXS w/1.25" (31.8mm)port	CVS13A9206X312	CVS13A9206X372
				1.125	29	M-Form w/1" (25.4mm)port	CVS11A3429X232	CVS1L199035162
						M-Form w/1.25" (31.8mm)port	CVS11A3429X232	CVS1L199035162
						M-Form w/1.5" (38.1mm)port	CVS11A3429X232	CVS1L199035162
						HPAXS w/1.25" (31.8mm)port	CVS13A9206X332	CVS13A9206X392
						HPX, HPAXS w/1.875" (47.6mm)port	CVS1K778335162	CVS11A3429X922
						HPX, HPAXS w/1.875" (47.6mm)port	CVS11A3429X232	CVS1L199035162
				1.5	38	M-Form w/1.5" (38.1mm)port	CVS1L2687X0012	CVS11A3429X452
						HPX, HPAXS w/1.875" (47.6mm)port	CVS1L2687X0012	CVS11A3429X452
				0.75, 1.125, 1.5	19, 29, 38	M-Form HPX, HPAXS w/1.5", 1.875" (38.1, 47.6mm)port	CVS1K744735162	CVS1L9086X00A2
						HPAXS w/1.25" (38.1mm)port	CVS13A9206X352	CVS13A9206X412
	5, Type 667	1	25.4	0.75, 1.125, 1.5	19, 29, 38	M-Form HPX, HPAXS w/1.5", 1.875" (38.1, 47.6mm)port	CVS1K744735162	CVS1L9086X00A2
HPAXS w/1.25" (38.1mm)port						CVS13A9206X352	CVS13A9206X412	

Continued,

**Key 20: Valve Stem for Class 1500, continued.**

Valve Size, NPS	Yoke Boss Inches	Valve Stem Connection		Valve Stem Travel		Description	Material					
		Inches	mm	Inches	mm		316 SST Standard Bonnet					
3	2-13/16 And 3-9/16	1/2	12.7	1.5, 2	38. 50.8	HPX2D w/2.875" (73mm)port	CVS1U217935162					
						HPX5T w/2.875" (73mm)port	CVS1U4269X0012					
		3/4	19.1	1.5, 2	38. 50.8	HPX2D w/2.875" (73mm)port	CVS10A9265X122					
						HPX5T w/2.875" (73mm)port	CVA1P6696X0012					
						HPXS w/2.875" (73mm)port	CVS10A9265X202					
	5	1	25.4	1.5	38	HPX2D	CVS1K778335162					
						HPX5T	CVS1L2687X0012					
						HPXS	CVS1N325635162					
				2	50.8	HPX2D	CVS1L2687X0012					
						HPX5T	CVS1K928935162					
						HPXS	CVS1N6682X0032					
	5, Type 667	1	25.4	1.5, 2	38. 50.8	HPX2D	CVS1L144635162					
						HPX5T	CVS1K744736162					
						HPXS	CVS1L2687X0012					
4	2-13/16 And 3-9/16	3/4	19.1	1.5, 2	38. 50.8	HPX2D w/3.625" (92.1mm)port	CVS1L400135162					
						HPX2D w/2.875" (73mm)port	CVS1L400135162					
						HPX5T w/3.625" (92.1mm)port	CVS10A6088X012					
						HPX5T w/2.875" (73mm)port	CVS1K587935162					
						5	1	25.4	1.5	38	HPX2D w/3.625" (92.1mm)port	CVS1K7891X0012
											HPX2D w/2.875" (73mm)port	CVS1L877635162
									2	50.8	HPX5T w/3.625" (92.1mm)port	CVS10A3282X012
											HPX5T w/2.875" (73mm)port	CVS1N325635162
	5, Type 667	1	25.4	1.5, 2	38. 50.8	HPX2D w/3.625" (92.1mm)port	CVS11A4329XN62					
						HPX2D w/2.875" (73mm)port	CVS1N325635162					
						HPX5T w/3.625" (92.1mm)port	CVS11A3429X232					
						HPX5T w/2.875" (73mm)port	CVS1N6682X0032					
						HPX2D w/3.625" (92.1mm)port	CVS11A3429X232					
						HPX2D w/2.875" (73mm)port	CVS1K778335162					
	HPX5T w/3.625" (92.1mm)port	CVS1P516435162										
	HPX5T w/2.875" (73mm)port	CVS1L2687X0012										

Continued.

**Key 20: Valve Stem for Class 1500, continued**

Valve Size, NPS	Yoke Boss Inches	Valve Stem Connection		Valve Stem Travel		Description	Material	
		Inches	mm	Inches	mm		316 SST Standard Bonnet	
6	2-13/16 And 3-9/16	3/4	19.1	2.5, 3	63.5, 76.2	HPX2D w/5.375" (136.5mm)port	CVS1J507135162	
						HPX5T w/5.375" (136.5mm)port		
	5	1	25.4	2.5	63.5	HPX2D w/5.375" (136.5mm)port	CVS10A3282X012	
						HPX2D w/4.375" (111.1mm)port	CVS1K778335162	
						HPX5T w/5.375" (136.5mm)port	CVS10A3282X012	
				HPX5T w/4.375" (111.1mm)port	CVS1K778325162			
				3	76.2	HPX2D w/5.375" (136.5mm)port	CVS11A4329X232	
						HPX2D w/4.375" (111.1mm)port	CVS1L2687X0012	
		HPX5T w/5.375" (136.5mm)port	CVS11A3429X232					
		1-1/4	31.8	2.5	63.5	HPX5T w/4.375" (111.1mm)port	CVS1L2298X0012	
						HPX2D w/5.375" (136.5mm)port		
						HPX2D w/4.375" (111.1mm)port		
				3	76.2	HPX5T w/5.375" (136.5mm)port		CVS10A6073X012
						HPX2D w/5.375" (136.5mm)port		
	HPX2D w/4.375" (111.1mm)port							
	1-1/4 X 2	31.8 X 50.8	2.5	63.5	HPX5T w/5.375" (136.5mm)port	Contact CVS Controls Ltd.		
					HPX2D w/5.375" (136.5mm)port			
	3	76.2	3	76.2	HPX5T w/5.375" (136.5mm)port	Contact CVS Controls Ltd.		
					HPX2D w/5.375" (136.5mm)port			

Continued,

**Key 20: Valve Stem for Class 1500, continued**

Valve Size, NPS	Yoke Boss Inches	Valve Stem Connection		Valve Stem Travel		Description	Material
		Inches	mm	Inches	mm		316 SST Standard Bonnet
6	5, Type 667	1	25.4	2.5, 3	63.5, 76.2	HPX2D w/5.375" (136.5mm)port	CVS11A3429X232
						HPX2D w/4.375" (111.1mm)port	CVS1L2687X0012
						HPX5T w/5.375" (136.5mm)port	CVS11A3429X232
						HPX5T w/4.375" (111.1mm)port	
		1-1/4	31.8	2.5, 3	63.5, 76.2	HPX2D w/5.375" (136.5mm)port	CVS10A6073X012
						HPX2D w/4.375" (111.1mm)port	
						HPX5T w/5.375" (136.5mm)port	
						HPX5T w/4.375" (111.1mm)port	
		1-1/4 X 2	31.8 X 50.8	2.5, 3	63.5, 76.2	HPX2D w/5.375" (136.5mm)port	Contact CVS Controls Ltd.
						HPX5T w/5.375" (136.5mm)port	

**Key 20: Valve Stem for Class 2500**

Valve Size, NPS	Yoke Boss, Inches	Valve Stem Connection		Valve Stem Travel		Description	Material
		Inches	mm	Inches	mm		316SST Standard Bonnet
2	2-13/16 And 3-9/16	1/2	12.7	0.75, 1, 1.125, 1.5	19.1, 25.4, 29, 38	M-Form HPX2D, HPX5T, HPXS	CVS1N821035162
		3/4	19.1	0.75, 1, 1.125, 1.5	19.1, 25.4, 29, 38	M-Form HPX2D, HPX5T	CVS1P6696X0012

## Key 12: Cages

Valve Size Inches	Cage Description	Travel		Material			
		Inches	mm	174-4 SST w/1075 Heat Treatment	SA-182-F22 Ion Nitride	316 SST Electrolyzed	NACE MR0175 17-4 SST H1150 DBL
2	Eq. Percentage	1-1/8, 1-1/2	28, 38	CVS32B6028X012	CVS32B6028X022	CVS32B6029X012	CVS32B6028X032
	Linear	1-1/2	38	CVS32B6025X012	CVS32B6025X022	CVS32B6026X012	CVS32B6025X032
3	Eq. Percentage	1-1/2, 2	38, 51	CVS42B824X012	CVS42B8240X022	CVS42B8241X012	CVS42B8240X032
	Linear	2	51	CVS42B8242X012	CVS42B8242X022	CVS42B8243X012	CVS42B8242X032
4	Eq. Percentage	1-1/2, 2	38, 51	CVS42B9220X012	CVS42B9320X022	CVS42B9231X012	CVS42B932X032
	Linear	2	51	CVS42B9322X012	CVS42B9322X022	CVS42B9323X012	CVS42B9322X032
6	Eq. Percentage	2-1/2, 3	64, 76	CVS43B0078X012	CVS43B0078X022	CVS43B0080X012	CVS43B0078X032
	Linear	3	76	CVS43B0079X012	CVS43B0079X022	CVS43B0081X012	CVS43B0079X032

## Key 22: Valve Plug for 2 to 6-inch CVS Controls Class 1500 Globe Valve

Valve Size Inches	Valve Design	Valve Stem Connection		Port Diameter		Material			
		In.	mm	In.	mm	Trim 2, 3 and 4 316 SST	Trim 2, 3 and 4 316 SST CoCr-A Seat / Guide	Trim 316 SST CoCr-A Seat/Guide	Trim 2, 3 and 4 416 SST
2	HPX2D	1/2	12.7	1-7/8	47.6	CVS32B6007X012	CVS32B6007X022	CVS32B6007X012	CVS32B6006X012
		3/4	19.1	1-7/8	47.6	CVS32B6008X012	CVS32B6008X022	CVS32B6008X012	CVS32B6008X012
	HPX5T	1/2	12.7	1-7/8	47.6	CVS32B6011X012	-----	CVS32B6011X012	CVS32B6010X012
		3/4	19.1	1-7/8	47.6	CVS32B6013X012	-----	CVS32B6013X012	CVS32B6012X012
3	HPX2D	1/2	12.7	2-7/8	73.0	CVS32B8247X022	CVS32B8247X032	CVS32B8247X012	CVS32B8246X012
		3/4	19.1	2-7/8	73.0	CVS32B8249X022	CVS32B8249X032	CVS32B8249X012	CVS32B8248X012
	HPX5T	1/2	12.7	2-7/8	73.0	CVS36A5429X012	-----	CVS36A5429X012	CVS36A5350X012
		3/4	19.1	2-7/8	73.0	CVS36A5430X012	-----	CVS36A5430X012	CVS36A5351X012
4	HPX2D	3/4	19.1	3-5/8	92.1	CVS32B9347X032	CVS36A5441X092 <sup>1</sup>	CVS36A5441X052	CVS36A5362X012
	HPX5T					CVS36A5437X132	CVS36A5441X102 <sup>2</sup>		
6	HPX2D	3/4	19.1	5-3/8	136.5	CVS36A5441X092	CVS36A5441X092 <sup>1</sup>	CVS36A5441X052	CVS36A5362X012
							CVS36A5441X102 <sup>2</sup>		
		1	25.4	5-3/8	136.5	CVS36A5442X102	CVS36A5442X102 <sup>1</sup>	CVS36A5442X042	CVS36A5363X012
							CVS36Z5442X112 <sup>2</sup>		
		1-1/4	31.8	5-3/8	136.5	CVS36A5443X082	CVS36A5443X082 <sup>1</sup>	CVS36A5443X042	CVS36A5364X012
							CVS38A6943X092 <sup>2</sup>		
	2	50.8	5-3/8	136.5	CVS36A943X072	CVS38A6943X072 <sup>1</sup>	CVS38A6943X042	CVS39A6740X012	
						CVS38A6943X082 <sup>2</sup>			
	HPX5T	3/4	19.1	5-3/8	136.5	CVS36A5444X012	-----	CVS36A5444X022	CVS36A5365X012
								CVS36A5445X012	
		1-1/4	31.8	5-3/8	136.5	CVS36A5446X012		CVS36A5446X012	CVS36A5367X012
								CVS38A8300X012	CVS38A8300X012

- For -20 to 650F (-29 to 353C) temperature range
- For 500 to 105F (260 to 566C) temperature range

**Key 28: Back-Up Ring for all Design HPX (2 to 6-inch) and HPAX (2-inch only) Valves**

Valve Size Inches	Port Diameter		Material	
	Inches	mm	S31600 (316 SST)	S41600 (416 SST)
2	1-7/8	47.6	CVS10A4218X012	CVS10A4218X022
3	2-7/8	73.0	CVS10A4217X022	CVS10A4217X012
4	2-7/8	73.0	CVS10A4217X022	CVS10A4217X012
	3-5/8	92.1	CVS16A5483S022	CVS16A5483X012
6	4-3/8	111.1	CVS10A4224X022	CVS10A4224X012
	5-3/8	136.5	CVS10A5409X022	CVS10A5409X012

**Gasket Set (Includes Key 19 Bonnet Gasket and Key 24 Seat Ring Gasket)**

Valve Rating Class	Valve Size, Inches	Material	
		N0660 (Inconel 600)/Graphite	NO 7750 (Inconel 750)/Graphite
1500	2 (std)	CVS12B7100X032	CVS12B7100X042
	3 (std)	CVS12B7100X052	CVS12B7100X062
	4 (std)	CVS12B7100X082	-----
	6 (std)	CVS12B7100X112	-----
2500	2 (std)	-----	CVS12B7100X132

**Key 23: Seat Ring**

Valve Size Inches	Design	Port Diameter		Seat Ring Material	
		Inches	mm	S41600 (316 SST)	S31600 316 SST CoCr-A Seat
2	HPX2D, HPX5T	1-7/8	47.6	CVS22B6004X012	CVS22B6005X012
3	HPX2D, HPX5T	2-7/8	73.0	CVS22B6094X012	CVS22B6095X012
4	HPX2D, HPX5T	3-5/8	92.1	CVS22B9338X012	CVS22B9339X012
	HPX2D, HPX5T	2-7/8	73.0	CVS22B9340X012	CVS22B9341X012
6	HPX2D, HPX5T	5-3/8	136.5	CVS23B0093X012	CVS23B0094C012
	HPX2D, HPX5T	4-3/8	111.1	CVS23B0096X012	CVS23B0096X012

# Dimensional Data

## Body Dimensions

Valve Size Inches	Dimension A (Globe Valve)					Dimension B (Globe Valve)				
	ANSI Flange Rating					ANSI Flange Rating				
	Class 900		Class 1500		Class 2500	Class 900		Class 1500		Class 2500
	Raised Face (RF)	Ring Type Joint (RTJ)	Raised Face (RF)	Ring Type Joint (RTJ)	Ring Type Joint (RTJ)	Raised Face (RF)	Ring Type Joint (RTJ)	Raised Face (RF)	Ring Type Joint (RTJ)	Ring Type Joint (RTJ)
	Inches	Inches	Inches	Inches	Inches	Inches	Inches	Inches	Inches	Inches
2	14.75	14.88	14.75	14.88	16.38	7.38	7.44	7.38	7.44	8.19
3	17.38	17.50	18.12	18.25	---	8.69	8.75	9.06	9.12	---
4	20.12	20.25	20.88	21.00	---	9.00	9.06	9.38	9.44	---
6	28.12	28.25	30.25	30.50	---	A/2	A/2	A/2	A/2	---

Valve Size Inches	Dimension A (Angle Valve)	
	ANSI Class 900 and 1500	
	Raised Face (RF)	Ring Type Joint (RTJ)
	Inches	Inches
2	7.00	7.06

## Standard Bonnet Dimensions

Valve Size Inches	Standard Bonnet Dimensions (Globe Valve) Class 900 and 1500			Class 2500 (Globe Valve)		Class 2500 (Globe Valve)	Standard Bonnet Dimensions (Angle Valve)			
	Dimension C	Dimension D		Dimension D		C	Dimension D			
		Yoke Boss Diameters (Inches)						Inches	Yoke Boss Diameters (Inches)	
		2-13/16	3-9/16	2-13/16	3-9/16	2-13/16	3-9/16			
2	3.06	10.31	10.56	11.91	11.91	3.31	8.94	9.19		
3	4.75	12.69	12.25	---	---	---	---	---		
4	6.88	---	11.81	---	---	---	---	---		
6	9.75	---	14.38	---	---	---	---	---		

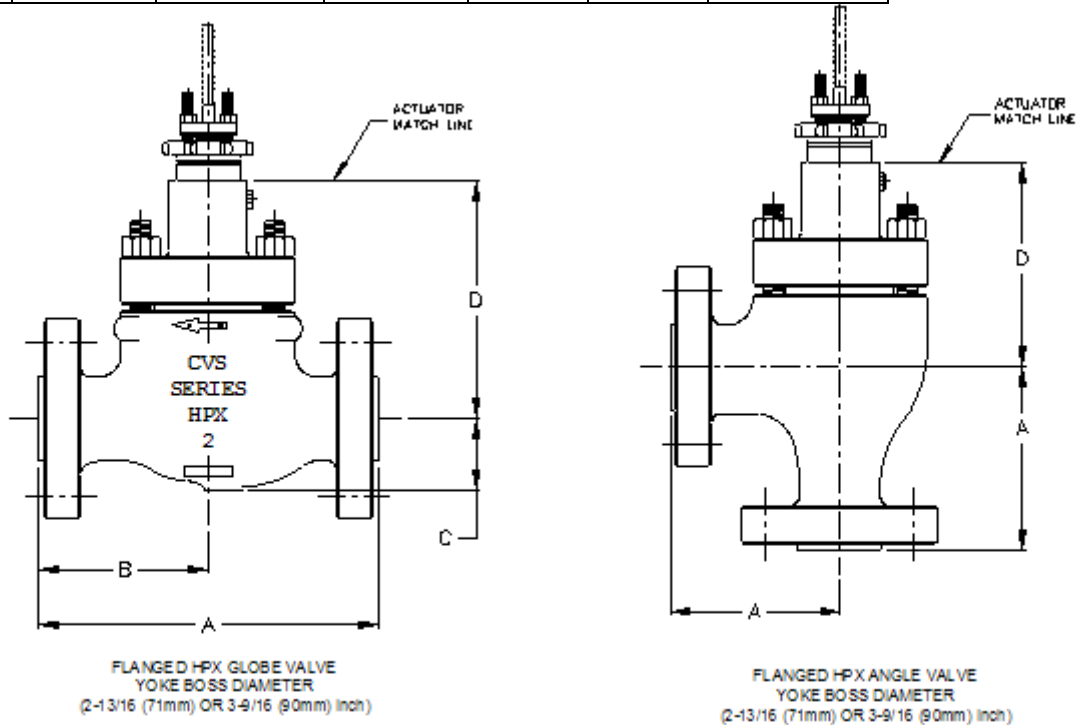

FIGURE 7. GLOBE AND ANGLE VALVE DIMENSIONS WITH STANDARD BONNET

# CVS

---

---

## Controls Ltd.

### **Head Office**

3900 – 101 Street  
Edmonton, Alberta, Canada T6E 0A5  
Office: (780) 437-3055  
Fax: (780) 436-5461

### **Calgary Sales Office**

205, 2323 – 32 Avenue NE  
Calgary, Alberta, Canada T2E 6Z3  
Office: (403) 250-1416  
Fax: (403) 291-9487

Website: [www.cvs-controls.com](http://www.cvs-controls.com) E-Mail: [info@cvs-controls.com](mailto:info@cvs-controls.com)

CVS Controls Ltd. strives for the highest levels of quality and accuracy. The information included in this publication is presented for informational purposes only. CVS Controls Ltd. reserves the right to modify or change, and improve design, process, and specifications without written notice. Under no circumstance is the information contained to be interpreted to be a guarantee/warranty with regard to our products or services, applicability or use. Selection, use and maintenance are the sole responsibility of the end user and purchaser. CVS Controls assumes no liability for the selection use and maintenance of any product.