

# CVS

## Controls Ltd.

### INSTRUCTION MANUAL

## CVS Series DBQ and DBAQ Control Valves

### Introduction

Contained in this manual are installation instructions, maintenance and parts information for the CVS DBQ and DBAQ Control Valves. Refer to the appropriate manuals for instructions for the accompanying actuator, positioner and additional accessories.

Only trained or experienced personnel should carry out the operation and installation of all pressure equipment. If you have any questions regarding the equipment, contact your CVS Controls representative.

### Applications and Features

The CVS Series DBQ and DBAQ Control Valves are ideally suited for high pressure water and steam applications, providing excellent pressure and flow control. This design may be utilized in both high pressure and high temperature control service.

CVS Series DBQ is a globe style valve, while the CVS Series DBAQ is an angle style valve, which may be used in angle piping or self draining applications.



Figure 1: 2" CVS Series DBAQ

Valve bodies are available in 1 or 2 inch sizes, with casted flanged connections, and ASME body ratings of Class 1500, or Class 2500. LCC, WCB and CF8M are standard body materials. Additional materials may be available upon request.

Sour Service Capability

Optional NACE MRO175/ISO 15156-2009

### Flow Characteristic

This design's flow characteristic is up through the seat ring and out through the cage. The CVS DBQ and DBAQ series valves are single port, metal seated valves.

#### Head Office

3900 101 Street  
Edmonton, Alberta  
T6E 0A5  
Canada

Office: (780) 437-3055

Fax: (780) 436-5461

# CVS

---

## Controls Ltd.

Website: [www.cvs-controls.com](http://www.cvs-controls.com)

Email: [info@cvs-controls.com](mailto:info@cvs-controls.com)

#### Calgary Sales Office

3516 114 Avenue SE  
Calgary, Alberta  
T2Z 3V6  
Canada

Office: (403) 250-1416

Fax: (403) 291-9487

## SPECIFICATIONS

Table 1: Specifications

<b>End Connection Style</b>	Flanged raised Face (RF)	ASME Class 1500, or Class 2500 (ASME B16.34-latest edition)
	Flanged Ring Type Joint (RTJ)	ASME Class 1500, or Class 2500 (ASME B16.34-latest edition)
<b>Maximum Inlet Pressure*</b>	Raised Face Flange	Consistent with Class 1500 or Class 2500 per ASME B16.34-latest edition
	Ring Type Joint	Consistent with Class 1500 or Class 2500 per ASME B16.34-latest edition
<b>Shutoff Classification</b>	Standard	Class IV – leakage of less than .01% of maximum capacity, using air at 50 psid
	Optional	Class V – leakage of less than .0005cc per minute, per inch of port diameter per psid using water at service pressure drop
<b>Flow Direction</b>	Taper Plug and M-Form Trims	Up through the seat ring and out through the cage
<b>Flow Characteristic</b>	Refer to Table 2.	
*Pressure and temperature limits in this manual, and any applicable standard should not be exceeded		

Table 2: Yoke Boss, Stem, Port, and Travel Specifications in inches (mm)

Body Size	Yoke Boss Diameter	Stem Diameter	Standard Cage and Seat Ring Combinations			
			M-Form Plug		Taper Plug	
			Port Diameter	Rated Travel	Port Diameter	Rated Travel
1	2-13/16* (71)	1/2* (12.7)	1/4, 3/8, 1/2, 3/4, 1**	3/4, 1***	3/4 (19.1)	3/4 * (19)
	3-9/16 (90)	3/4 (19.1)	(6.4, 9.5, 12.7, 19.1, 25.4)	(19, 25)	1 (25.4)	1 (25)
	5 (127)	1, 1-1/4 (25.4, 31.8)				
2	3-9/16* (90)	3/4* (19.1)	1/4, 3/8, 1/2, 3/4, 1, 1-1/4	3/4*, 1***	3/4, 1, 1-1/4	1* (25)
	5 (127)	1, 1-1/4 (25.4, 31.8)	(6.4, 9.5, 12.7, 19.1, 25.4, 31.8)	(19, 25)	(19.1, 25.4, 31.8)	1-1/8* (29)
*Standard Configuration						
**Not available in Class 2500 bodies						
***Flow Characteristic is slightly sacrificed						

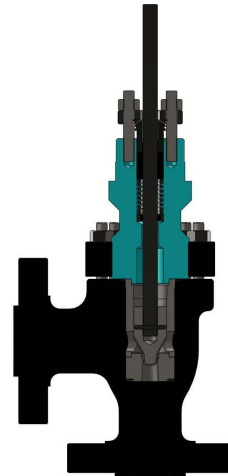
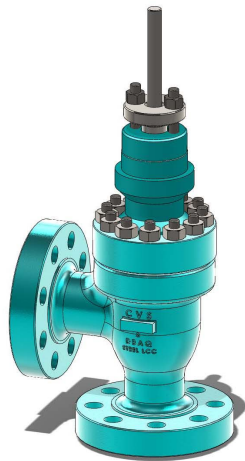

CVS Series DBAQ

---

## INSTALLATION

---

Exceeding the recommended pressure and temperature limits from Table 1, or those indicated on the nameplates of your CVS Controls Valve, can result in personal injury and property damage. CVS Controls recommends the installation of a relief valve to protect against overpressure situations.

**CVS Series DBQ and DBAQ are designed to meet specific conditions for fluid control, temperature, pressure and pressure drop. The limiting factor on these valves can be the body/trim material combinations. Do not install these valves in any other applications without first consulting with your CVS Controls representative.**

1. Inspect the valves for shipping damage and foreign debris while uncrating.
2. Ensure the pipeline is free from welding slag, chips and other debris by blowing out the line before installation.
3. Position the valve on the line so the flow direction indicator corresponds to the direction of the flow of the pipeline.
4. CVS Controls recommends the installation of a standard three-valve maintenance bypass. This will allow the isolation of the control valve without shutting down the pipeline system.
5. Install approved gaskets between the valve body and the pipeline flanges.
6. If the actuator has been shipped separately, refer to the mounting procedure in the applicable instruction manual.
7. If the valve body arrives without packing installed in the packing box, it will be necessary to install the packing before putting the valve into service. To complete these procedures, follow the instructions under *packing maintenance* in this manual.

8. **\*Note:** It may be necessary to adjust the packing to prevent leakage. Prior to shipping the packing was tightened, and may require some adjustment for specific conditions.

---

## MAINTENANCE

---

Internal valve components are subject to normal deterioration and must be inspected and replaced as required. The necessity of inspections and replacement of parts will depend on the severity of service conditions. Inspections and maintenance must be carried out on a regularly scheduled basis.

To ensure the safety of personnel and to protect against property damage, the following steps should be carried out before beginning disassembly.

1. To prevent the valve from opening suddenly, disconnect any operating lines to the actuator. This would include air pressure, electrical power or control signal lines.
2. Isolate the valve by using the bypass valve, or by shutting down the process completely. Relieve the pressure and drain the process fluid from both sides of the valve.
3. Relieve the pressure contained in the actuator by venting the actuator loading pressure and relieving any power actuator spring compression.
4. Lock-out procedures should be strictly adhered to while the equipment is being serviced.
5. To ensure a good gasket seal, the gasket should be replaced upon re-assembly whenever it becomes disturbed by removing or shifting gasketed parts.

---

## PACKING LUBRICATION

---

These instructions are for the lubricator or lubricator isolation valve (Figure 2). If the lubricator or lubricator isolation valve have been installed, they will be in place of the pipe plug and are designed for packing that requires lubrication, including PTFE composition. CVS Controls recommends a silicone based lubricant. Lubricant is not recommended for oxygen services or for processes that operate in excess of 500F (260°C). To add lubricant to the packing box, turn the capscrew in a clockwise direction.

---

### For Lubricator/Isolating Valve

---

1. Open the isolating valve.
2. Turn the capscrew in a clockwise direction.
3. Close the isolating valve.

---

## PACKING LEAKAGE

---

### Spring-Loaded PTFE V-Ring Packing

To eliminate leakage, tighten the packing flange nuts (key 18, figure 7). If leakage cannot be controlled in this manner, the packing will need to be replaced.

### Other Packing

If packing other than Spring-Loaded PTFE V-Ring has been used, attempt to eliminate the leaking and create a stem seal by tightening the packing flange nuts to the minimum recommended torque given in Table 5. If leakage continues, the packing will need to be replaced.

---

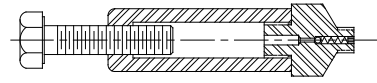

**LUBRICATOR**

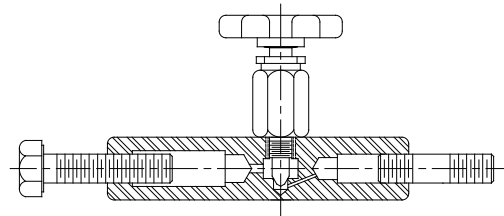

**LUBRICATOR/ISOLATING VALVE**

**Figure 2: Lubricator and Lubricator Isolating Valve**

---

### New Packing

---

If tightening the appropriate flange nuts does not solve the leakage problem and the packing is relatively new, leakage could indicate damage to the packing box wall or to the stem. Inspect the valve stem plug for a good surface finish as well as the packing box wall for nicks and scratches that could compromise the seal.

### *Hint:*

If leakage originates from the outside diameter of the packing, check the packing box wall for nicks or scratches. If leakage originates from the inside diameter of the packing, check the stem for nicks or scratches.

**Table 3: Recommended Torque for Packing Flange Nuts**

Stem Diameter		Valve Class Rating	Lbf•Ft		N•M	
Inch	mm		Min	Max	Min	Max
1/2	12.7	1500	11	16	15	22
		2500	13	18	18	24
3/4	19.1	1500	25	37	34	50
		2500	30	45	41	61
1	25.4	1500	38	57	52	77
		2500	45	67	61	91
1-1/4	31.8	1500	50	75	68	102
		2500	60	90	81	122

---

### ADDING PACKING RINGS

---

When using packing with lantern ring it may be possible to add packing rings above the lantern ring as a temporary measure without removing the actuator from the valve body.

1. Isolate the control valve from the line pressure and release the pressure from the valve body.
2. Remove the packing flange nuts (key 18, Figure 7) and lift the packing flange (key 16), upper wiper (key 20) and packing follower (key 21, Figure 7) away from the valve body.
3. Take care when removing out the old packing rings to avoid scratching the valve plug stem or packing wall. Clean all metal parts to remove debris that would prevent the packing from sealing properly.
4. Should split ring packing be added, spread the rings over the stem and slide the rings into the packing box. Alternate the position of the splits to avoid creating a leak path. If solid ring packing is being added, remove the stem connector and slip the rings over the end of the valve stem.
5. Re-assemble the packing follower, upper wiper, packing flange, and packing flange nuts. (keys 21, 20, 16, and 18).

6. Reconnect the body actuator stem connection according to the appropriate manual. Torque accordingly, reference Table 3.

---

### REPLACING PACKING

---

Prior to beginning any maintenance, it is important to isolate the valve from the line pressure, and to release all pressure from the valve body. Disconnect all operating lines to the actuator, including air pressure, electrical power or control signal lines. The process pressure should be released both upstream and downstream of the valve. Drain the process fluid from both sides of the valve.

Employ lockout procedures to ensure the safety of personnel and equipment during the valve service.

**NOTE: Extreme caution must be used during the disassembly. Nicks and scratches will affect the ability to seal the valve in the future.**

1. Remove the capscrews in the stem connector and separate the two halves. Exhaust all actuator pressure if any was applied, and disconnect the actuator supply and leak off piping.
2. Remove the yoke locknut, and remove the actuator from the bonnet (key 2).
3. Loosen the packing flange nuts (key 18), and remove any travel indicator parts and stem locknuts from the valve stem threads

### Replacing Packing Continued,

4. Unscrew hex nuts (key 8) and remove the bonnet off the valve stem. Ensure the valve plug and stem remain in the body and on the seat. This will prevent damage to the seating surfaces as a result of the assembly dropping from the bonnet after being lifted out.
5. Should the valve plug and stem assembly start to lift out, use a brass hammer on the end of the stem and tap it back down. Set the bonnet on a cardboard or wooden surface to prevent damage to the bonnet gasket surface.
6. Upon removing the bonnet gasket (key 5), cover the opening in the valve body to protect the surface and prevent any debris from getting into the valve body.
7. Remove the packing flange nuts, packing flange, upper wiper and packing follower (keys 18, 16, 20 and 21). Carefully push the remaining parts out from the body side of the bonnet. Take care not to scratch the packing box wall. Clean the box and metal parts.
8. Inspect components such as valve stem threads and packing box for any sharp edges that may damage the packing. If the surfaces cannot be improved by light sanding, replace the damaged parts. Scratches or burrs may cause packing leakage.
9. Remove the protective covering from the valve body. Install a new bonnet gasket (key 5). Ensure the gasket seating surfaces are clean and clear of debris. Check that the M-Flat valve plug, and stem assembly are oriented as shown in Figure 5 when replacing the bonnet to the valve body. Slide the bonnet over the stem onto the stud bolts.

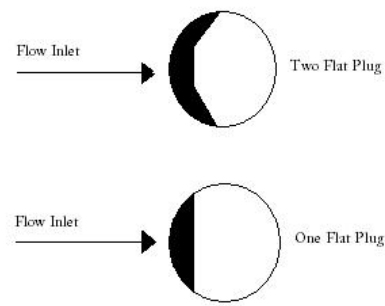

**Figure 5: M-Flat Valve Plug Orientation**

10. Replace the packing hex nuts (key 18)
  - 10a. For pre lubricated hex nuts (identified by black film coating on the nut threads) tighten the hex nuts finger tight.
  - 10b. For all other nuts, CVS Controls recommends that you lubricate the stud threads with Never Seez pure Nickel special lubricant or equivalent.
11. To center trim, the valve will need to be stroked several times. Using proper bolting procedures tighten the nuts to no more than 1/4 of the torque values specified in Table 4.
12. Increase the torque on each nut by an additional 1/4 of the torque value using the standard crisscross pattern. Repeat this pattern until the torque values in Table 4 have been reached. Apply the final torque value again and if any bolts turn, all of the bolts will require re-tightening.
13. Using the appropriate packing arrangement, install new packing and metal packing box parts. It may be necessary to pre-lubricate packing parts with a silicone based grease.
14. Using a smooth edged pipe, cautiously tap each soft packing part into the packing box. To prevent trapping air between the rings, add one ring at a time, without forcing them below entrance chamber of the packing box. With each additional ring the stack should only be pushed down the thickness of one ring.

## Replacing Packing Continued,

15. Install the packing follower, wiper and packing flange. Lubricate the packing flange studs (key 17) and faces of the packing flange nuts (key 18). Replace packing flange nuts.

16. For spring loaded PTFE V-Ring packing, tighten the packing flange nuts until the shoulder on the packing follower (Key 21) contacts the bonnet. For other packing types, tighten the packing flange nuts in small increments alternately. Repeat until the maximum recommended torque is reached, shown in Table 3.

17. Mount the actuator on the valve body and reconnect the valve plug stems according to the appropriate actuator instruction manual.

Valve Size Inch	Valve Rating ASME Class	Lbf•Ft	N•m
1	1500	130	176
	2500	191	259
2	1500	104	141
	2500	281	381

Table 4: Recommended Torque for Body to Bonnet Bolting

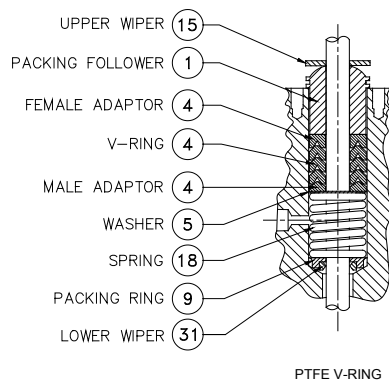

PTFE V-RING

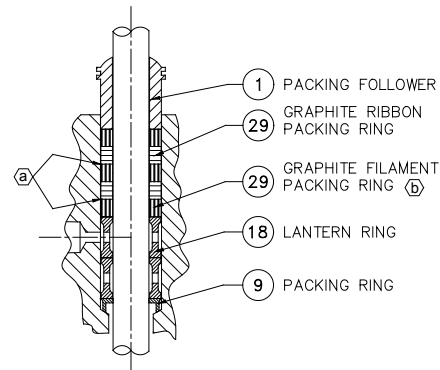

GRAPHITE RIBBON AND FILAMENT

### SINGLE PACKING

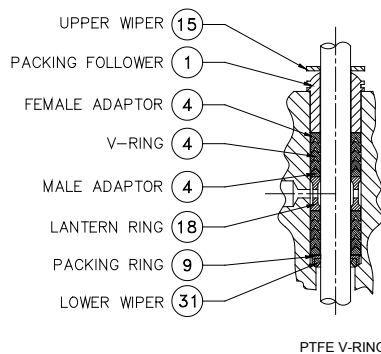

PTFE V-RING

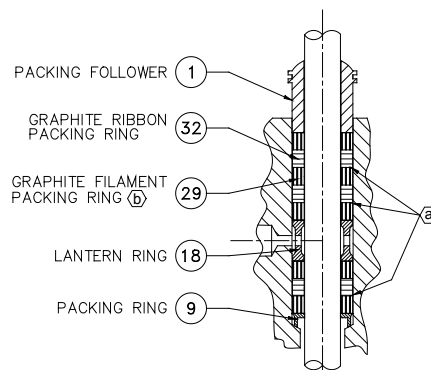

GRAPHITE RIBBON AND FILAMENT

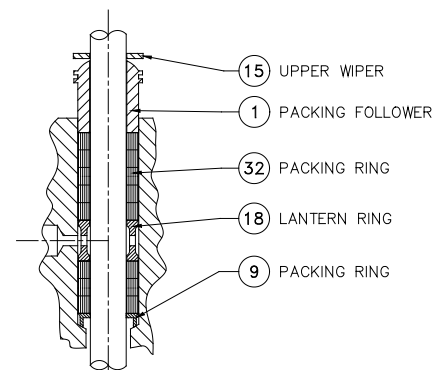

PTFE/COMPOSITION

### DOUBLE PACKING

#### NOTES:

- Ⓐ ZINC WASHER, ONE USED BELOW EACH GRAPHITE RIBBON RING.
- Ⓑ HAS THE APPEARANCE OF A WOVEN OR BRAIDED RING.

---

## TRIM MAINTENANCE

---

### Disassembly

1. Remove the actuator from the bonnet. Refer to steps 1 thru 5 of *Replacing Packing* procedure. Observe all warnings and cautions.

**NOTE: Avoid damaging gasket sealing surfaces. The surface finish of the valve stem is critical for ensuring a tight seal. The seating of the seat ring and valve plug are critical for tight shutoff. Replace accordingly should an inspection show damage.**

2. Carefully lift the valve plug and stem assembly, cage, seat ring and seat ring gasket out of the valve body. If the valve plug is being re used, take care to protect the valve plug stem and valve plug seating surface from scratches or damage.
3. Inspect all components for wear or damage that would prevent proper operation of the valve. Replace or repair trim parts accordingly. Refer to *Lapping Metal Seats* or *Trim Replacement* as required.

---

### Lapping Metal Seats

---

With metal to metal seating in any valve, a small amount of leakage can be expected. If the leakage becomes excessive, it is possible to improve shutoff by seat lapping of the valve plug and seat ring.

Deep nicks may be machined, rather than ground out.

Apply a good quality lapping compound mixture of 280 to 600 grit to the bottom of the valve plug.

Secure the seat ring using a vise, and hold the cage against the seat ring to properly align the valve plug and seat ring while grinding.

Once completed, clean the seating surfaces thoroughly and test for shutoff. Repeat the lapping process if leakage is still excessive.

### Assembly

Upon completion of trim maintenance or replacement, reassemble the valve body using the following procedure. Ensure all gasketed surfaces have been thoroughly cleaned.

1. Install the seat ring gasket (key 6) and the seat ring (key 11) into the valve body.
2. For standard cage installation, align two of the holes in the cage with the centerline of the valve body.
3. Install the valve plug and stem assembly (key 4) into the cage. Ensure the m-flat valve plug orientation is as shown in Figure 5 when replacing the bonnet.
4. Install the bonnet gasket (key 5) and bonnet (key 2) over the valve stem and onto the body.



## Assembly Continued,

5. Lubricate the bolting, unless pre lubricated bolt nuts are being used. Replace the hex nuts finger tight. Torque the nuts using proper bolting procedures in a crisscross pattern to no more than 1/4 of the nominal torque value specified in Table 4. After all nuts have been initially torque, increase the torque by 1/4 of the specified nominal torque using proper bolting procedures again. Repeat the process until all nuts are tightened to the specified nominal value. Apply final torque once again, should any nut still turn, repeat the torque process on all nuts.
6. Install new packing box parts using steps 11 thru 13 of the replacing packing procedure.

**NOTE: Should minor adjustments be required, re clamp the actuator and valve stems together. Do not screw the valve stem in or out of the stem connector as this may change the orientation of the valve plug shown in Figure 5.**

7. Mount the actuator using correct procedures referenced in the appropriate actuator manual. Check for packing leakage when putting the valve into service. Re-torque packing flange nuts as required.

---

## PARTS ORDERING

---

The CVS DBQ and DBAQ Series Valves are identified by a serial number located on the valve body. Please reference this number when contacting a CVS Controls Ltd. Representative for technical support or part inquiries.

When shipped as part of a complete valve assembly with a CVS Controls actuator, the same valve serial number can be found on the actuator nametag as well as the valve body.

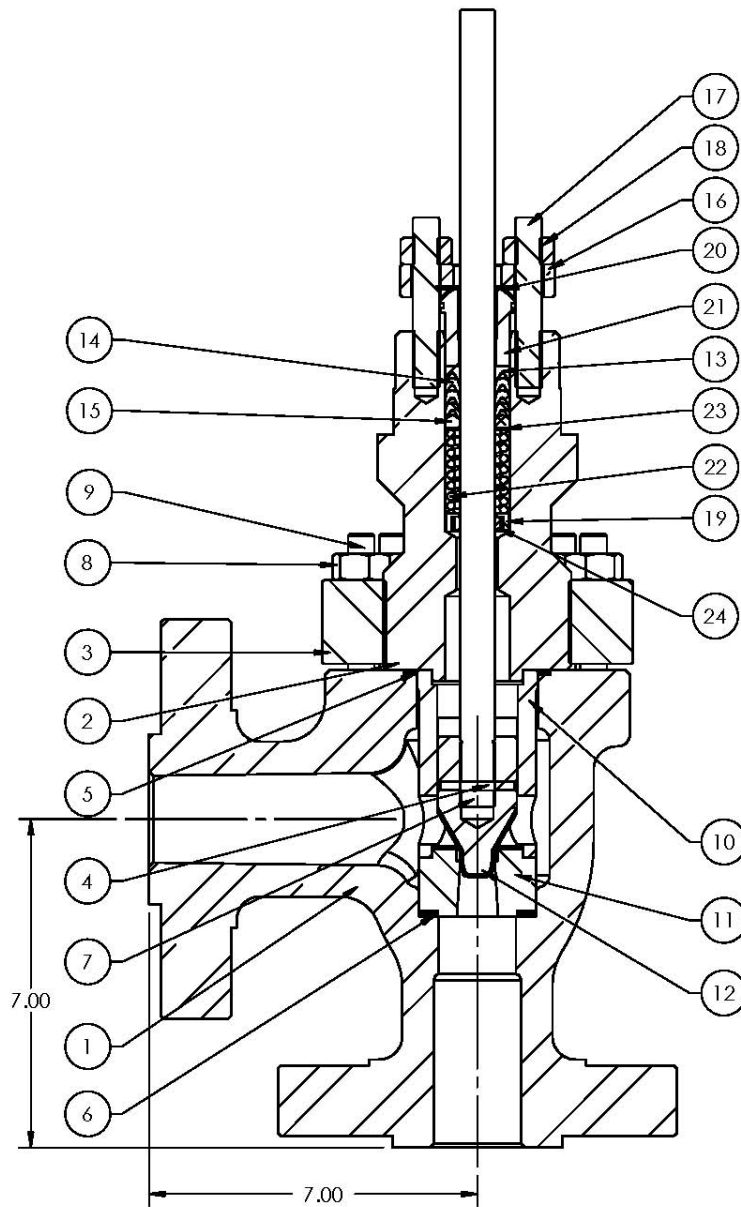

**Figure 7: 2" CVS SERIES DBAQ**

Item	Description	Item	Description
1	Body, LCC, 900/1500#, RF	13	Packing Set, Upper Packing, PTFE
2	Bonnet, LCC, 3-9/16 Yoke Boss	14	Packing Set, Center Packing, PTFE
3	Bonnet Flange, LCC	15	Packing Set, Lower Packing, PTFE
4	Pin, $\phi$ .187, 316 SST	16	Packing Flange, Steel
5	Bonnet Gasket	17	Packing Flange Stud, Steel
6	Seat Ring Gasket	18	Packing Flange Nut, Steel
7	3/4" Stem, 316 SST	19	Packing Box Ring, 316 SST
8	Hex Nut, 9/16", ASME SA-194-2H	20	Upper Wiper, Felt
9	Stud Bolt, 9/16"x3.78, ASME SA-193-B7	21	Packing Follower, 316 SST
10	Cage	22	Packing Spring
11	Seat Ring	23	Special Washer
12	Plug	24	Lower Wiper, Felt

**PARTS LISTING – 2" CVS SERIES DBAQ – Table 5**

Item	Description	Part Number	Quantity
1	Body, CVS Series DBAQ, 2", LCC, 900/1500# RF	CVS 2U967522012	1
2	Bonnet, LCC, 3-9/16 Yoke Boss, 2" CVS DBAQ	CVS 2N1363X0022	1
3	Bonnet Flange, LCC, 2" CVS DBAQ	CVS 1N339222012	1
4*	Pin*, Valve Stem/Plug Assembly, (3/4" Stem)	See Table 6	1
5	Bonnet Gasket, 2" CVS DBAQ, HT	CVS 1L120899442	1
6	Seat Ring Gasket, 2" CVS DBAQ, HT	CVS 1N297899442	1
7*	Stem*, 3/4", 316 SST, Valve Stem/Plug Assembly	See Table 6	1
8	Hex Nut, 9/16", ASME SA-194-2H	CVS 1C330624072	12
9	Stud Bolt, 9/16"x3.78, ASME SA-193-B7	CVS 1R387331012	12
10	Cage, Equal Percent, 17-4/HT1150	CVS 1P892339022	1
11	Seat Ring	CVS 1U274346052	1
12*	Plug*, Valve Stem/Plug Assembly, Alloy 6	See Table 6	1
13**	Packing Set**, Upper Packing, PTFE	See Table 7	1
14**	Packing Set**, Center Packing, PTFE	See Table 7	3
15**	Packing Set**, Lower Packing, PTFE	See Table 7	1
16	Packing Flange, 3/4", Steel	CVS 1E9448	1
17	Packing Flange Stud, Steel	CVS 1E9449	2
18	Packing Flange Nut, Steel	CVS 1E9446	2
19	Packing Box Ring, 316 SST	CVS 1J8733	1
20	Upper Wiper, Felt, 3/4"	CVS 1J8728	1
21	Packing Follower, 316 SST, 3/4"	CVS 1E9447	1
22	Packing Spring	CVS 1F1256	1
23	Special Washer, 3/4" SST	CVS 1F1250	1
24	Lower Wiper, TFE, 3/4"	CVS 1J8723	1
*Valve Stem, Valve Plug and Pin Sold as Assembly – See Table 6			
** Items 12, 13 and 14 - Part of a complete Packing Set – See Table 7			

**Table 6:**

Item	Description	Part Number	Quantity
4, 7, 12	Valve Stem and Plug Assembly, Alloy 6, 3/4"	CVS 2U5986X0012	1

**Table 7:**

Item	Description	Part Number	Quantity
13, 14, 15	PTFE Packing Set, 3/4"	CVS 1R2904	1

## CVS Series DBQ Dimensions

Nominal Body Size Inch	A				D				G (Maximum)	
	Class 900/1500		Class 2500		Standard Bonnet		Ext. Bonnet		Class 900/1500	Class 2500
	RF, Flanged, or Weld Ends	RTJ Flanged Ends	RF, Flanged, or Weld Ends	RTJ Flanged Ends	1/2" (12.7mm) Stem	3/4" (19.1mm) Stem	1/2" (12.7mm) Stem	3/4" (19.1mm) Stem	Class 900/1500	Class 2500
<b>Inches</b>										
1	10.00	10	12.13	12.13	8.31	9.38	15.38	16.00	1.81	2.12
2	12.13	12.25	15.38	15.50	9.75	10.50	16.81	17.44	2.75	3.25
<b>mm</b>										
1	254	254	308	308	211	238	391	406	46	54
2	308	311	391	394	248	267	427	443	70	83

## CVS Series DBQ Dimensions

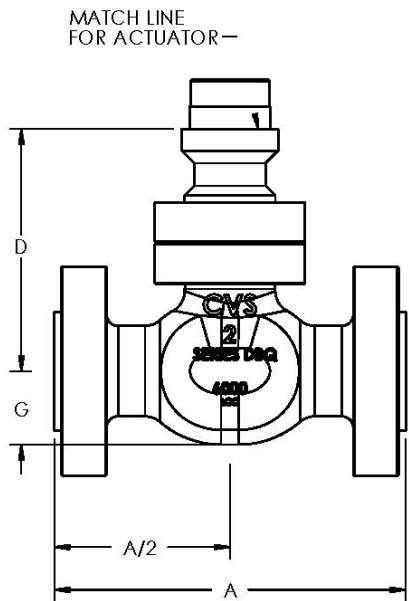

CVS Series DBQ – Plain Bonnet

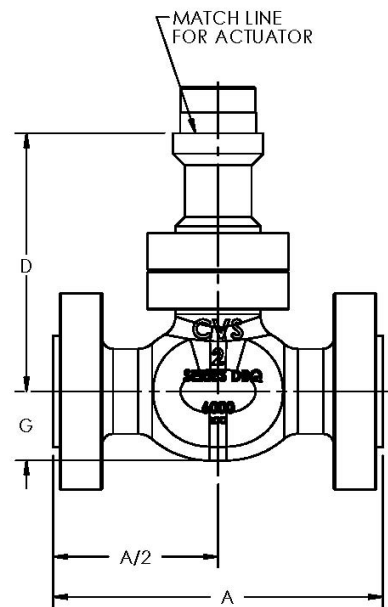

CVS Series DBQ – Extension Bonnet

## CVS Series DBAQ – Product Bulletin: Dimensions

Nominal Body Size Inch	A				D			
	Class 900/1500				Class 900/1500			
	Class 900/1500		Class 2500		Std Bonnet		Ext. Bonnet	
	RF, Flanged, or Weld Ends	RTJ Flanged Ends	RF, Flanged, or Weld Ends	RTJ Flange Ends	1/2" (12.7mm) Stem	3/4" (19.1mm) Stem	1/2" (12.7mm) Stem	3/4" (19.1mm) Stem
<b>Inches</b>								
1	5.56	5.56	6.06	6.06	8.31	9.38	15.38	16.00
2	7.00	7.06	7.69	7.75	9.75	10.50	16.81	17.44
<b>mm</b>								
1	141	141	154	154	211	238	391	406
2	179	179	195	197	248	267	427	443

Nominal Body Size Inch	D			
	Class 2500			
	Standard Bonnet		Extension Bonnet	
	1/2" (12.7mm) Stem	3/4" (19.1mm) Stem	1/2" (12.7mm) Stem	3/4" (19.1mm) Stem
<b>Inches</b>				
1	6.94	8.00	14.00	14.62
2	8.25	9.00	15.31	15.94
<b>mm</b>				
1	176	203	356	371
2	210	229	389	405

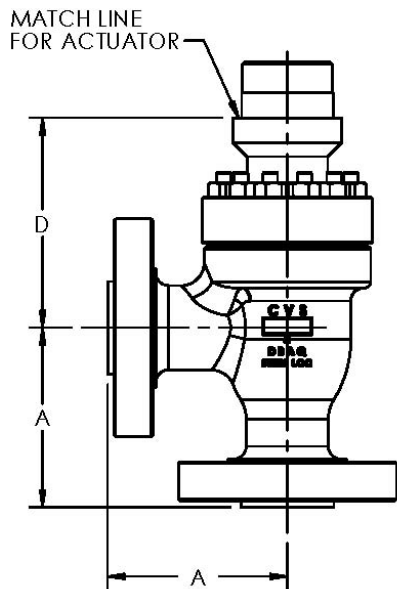

CVS Series DBAQ – Plain Bonnet

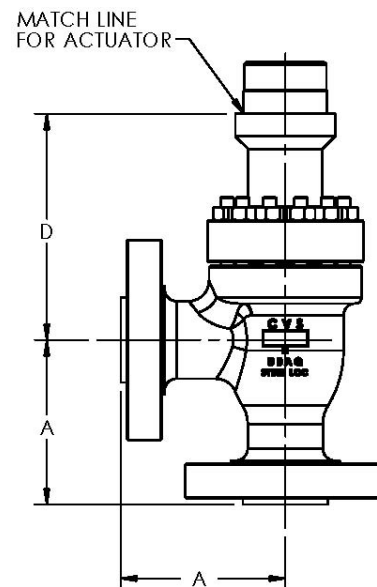

CVS Series DBAQ – Extension Bonnet

# CVS Series DBAQ: Product Bulletin

## Flow Coefficients: M-Form Valve Plug

Flow Up – Equal Percent															
Body Size (Inches)	Port Diameter		Total Travel		Valve Opening – Percentage of Total travel										F <sub>L</sub> *
	In.	mm	In.	mm	10	20	30	40	50	60	70	80	90	100	
<b>C<sub>V</sub></b>															
1	1/4	6.4	3/4	19	.067	.109	.170	.237	.324	.449	.632	.891	1.27	1.62	.95
	3/8	9.5	3/4	19	.121	.163	.271	.443	.616	.887	1.29	1.82	2.47	3.19	.97
	1/2	12.7	3/4	19	.230	.425	.603	.861	1.19	1.65	2.25	3.07	4.14	5.38	.95
	3/4	19.1	3/4	19	.265	.531	.871	1.38	2.03	3.01	4.58	6.67	8.5	9.66	.89
			1 <sup>a</sup>	25 <sup>a</sup>	---	---	---	---	---	---	---	---	---	11.0	.89
2	1/4	6.4	3/4	19	.103	.137	.184	.243	.321	.440	.628	.875	1.21	1.59	.97
	3/8	9.5	3/4	19	.101	.168	.263	.399	.585	.850	1.22	1.73	2.45	3.27	.97
	1/2	12.7	3/4	19	.193	.380	.561	.794	1.12	1.58	2.23	3.16	4.33	5.55	.97
	3/4	19.1	3/4	19	.378	.634	.971	1.44	2.12	3.16	4.75	6.96	9.48	11.7	.95
	1	25.4	3/4	19	.684	1.08	1.66	2.52	3.80	5.72	8.52	12.5	16.1	19.2	.92
	1-1/4	31.8	3/4	19	.885	1.28	1.81	2.69	4.27	6.48	9.48	13.3	19.0	23.1	27.2
			1 <sup>a</sup>	25 <sup>a</sup>	---	---	---	---	---	---	---	---	---	33.8	.92
<b>X<sub>T</sub></b>															
1	1/4	6.4	3/4	19	.762	.548	.392	.419	.476	.548	.565	.582	.602	.666	--
	3/8	9.5	3/4	19	.369	.411	.341	.490	.639	.609	.589	.626	.679	.784	--
	1/2	12.7	3/4	19	.443	.585	.588	.557	.547	.565	.603	.647	.684	.780	--
	3/4	19.1	3/4	19	.843	.641	.596	.560	.566	.594	.601	.625	.659	.686	--
			1 <sup>a</sup>	25 <sup>a</sup>	---	---	---	---	---	---	---	---	---	.608	--
2	1/4	6.4	3/4	19	.482	.417	.420	.479	.522	.563	.548	.565	.591	.643	--
	3/8	9.5	3/4	19	.434	.306	.425	.537	.522	.519	.535	.569	.611	.720	--
	1/2	12.7	3/4	19	.792	.754	.687	.665	.635	.618	.600	.600	.663	.748	--
	3/4	19.1	3/4	19	.774	.647	.645	.649	.658	.651	.623	.624	.664	.731	--
	1	25.4	3/4	19	.647	.645	.659	.644	.623	.612	.614	.621	.721	.784	--
	1-1/4	31.8	3/4	19	.671	.629	.624	.598	.544	.343	.684	.711	.774	.774	--
			1 <sup>a</sup>	25 <sup>a</sup>	---	---	---	---	---	---	---	---	---	.698	--
Flow Down – Equal Percent															
<b>C<sub>V</sub></b>															
1	1/2	12.7	3/4	19	.452	.832	1.28	1.85	2.46	3.19	4.22	5.30	6.56	8.00	.56
	3/4	19.1	3/4	19	.600	1.10	1.76	2.93	4.05	5.18	6.70	8.49	10.0	10.8	.81
2	1/2	12.7	3/4	19	.452	.832	1.28	1.85	2.46	3.19	4.38	6.33	7.05	9.04	.55
	3/4	19.1	3/4	19	.600	1.10	1.71	2.40	3.23	4.90	7.10	9.43	12.6	16.9	.57
	1	25.4	3/4	19	1.19	2.00	2.92	4.15	5.83	8.05	10.7	14.5	19.0	24.1	.64
	1-1/4	31.8	3/4	19	1.85	2.73	3.55	5.15	6.21	9.76	16.7	25.2	32.3	35.5	.69
			1 <sup>a</sup>	25 <sup>a</sup>	---	---	---	---	---	---	---	---	---	38.3	.69
<b>X<sub>T</sub></b>															
1	1/2	12.7	3/4	19	.210	.162	.133	.125	.134	.144	.165	.196	.245	.303	--
	3/4	19.1	3/4	19	.195	.166	.160	.136	.155	.221	.280	.368	.493	.587	--
2	1/2	12.7	3/4	19	.210	.162	.123	.125	.134	.157	.168	.159	.254	.267	--
	3/4	19.1	3/4	19	.195	.166	.170	.202	.243	.239	.257	.328	.352	.314	--
	1	25.4	3/4	19	.158	.139	.152	.190	.218	.256	.312	.370	.413	.412	--
	1-1/4	31.8	3/4	19	.134	.115	.127	.145	.253	.325	.368	.371	.370	.404	--
			1 <sup>a</sup>	25 <sup>a</sup>	---	---	---	---	---	---	---	---	---	.461	--

\*At 100% Travel

<sup>a</sup>Valve travel may be up to 1 in. (25mm) with slight sacrifice in flow characteristic.

Note: K<sub>v</sub> = (0.865) (C<sub>v</sub>)

**Notes:**

---

CVS Controls Ltd. strives for the highest levels of quality and accuracy. The information included in this publication is presented for informational purposes only. CVS Controls Ltd. reserves the right to modify or change, and improve design, process, and specifications without written notice. Under no circumstance is the information contained to be interpreted to be a guarantee/warranty with regard to our products or services, applicability or use.

Selection, use and maintenance are the sole responsibility of the end user and purchaser. CVS Controls assumes no liability for the selection use and maintenance of any product.

# CVS

---

## Controls Ltd.

**Head Office**

3900 101 Street  
Edmonton, Alberta  
T6E 0A5  
Canada  
Office: (780) 437-3055  
Fax: (780) 436 5461

**Calgary Sales Office**

3516 114 Avenue SE  
Calgary, Alberta  
T2Z 3V6  
Canada  
Office: (403) 250-1416  
Fax: (403) 291-9487

Website: [www.cvs-controls.com](http://www.cvs-controls.com)

Email: [info@cvs-controls.com](mailto:info@cvs-controls.com)