

Instruction Manual

CVS Low Emission Chemical Injection Pump



Low Emission Chemical Pump



Applications

1. The introduction of de-emulsifiers, corrosion inhibitors, de-scaling agents, solvents and oxygen scavengers
2. Water treatment
3. Methanol injection in gas pipelines
4. Injection of surfactant (Soap) into low pressure gas wells with high water content

Description

The CVS Low Emission Chemical Injector Pump uses a pneumatic cylinder to mechanically force a plunger through one of several options of packing. This makes the unit a positive displacement reciprocating pump, capable of discharge pressures up to 10000 psi (690 bar). The stroke rate is controlled by adjusting the speed control valve from 1 to 60 SPM (strokes per minute), allowing for capacities up to 60 gallons (230 litres) per day.

This is a low consumption unit capable of running air or gas. The inlet pressure ranges from a minimum of 3 psi (0.206bar) to a maximum of 150 psi (10.342 bar). A choice of three plunger sizes, and controllable strokes per minute (SPM) with a slow speed controller. This allows for a wide range in capacity, from less than 1 quart to 60 gallons/day. This is a lightweight, reliable and rugged pump which is easily serviced in the field.

The chemical injector comes furnished with one or two fluid power heads. The fluid head comes with a stainless steel plunger, internal ball checks, adjustable type packing and a priming valve. The standard fluid end is ductile iron with stainless steel trim and plunger; all stainless steel is an available option.

Head Office
3900 – 101 Street
Edmonton, Alberta, Canada T6E 0A5
Office: (780) 437-3055
Fax: (780) 436-5461

CVS

Controls Ltd.

Calgary Sales Office
205, 2323 – 32 Avenue NE
Calgary, Alberta, Canada T2E 6Z3
Office: (403) 250-1416
Fax: (403) 291-9487

Website: www.cvs-controls.com E-Mail: info@cvs-controls.com

Dimensional Data

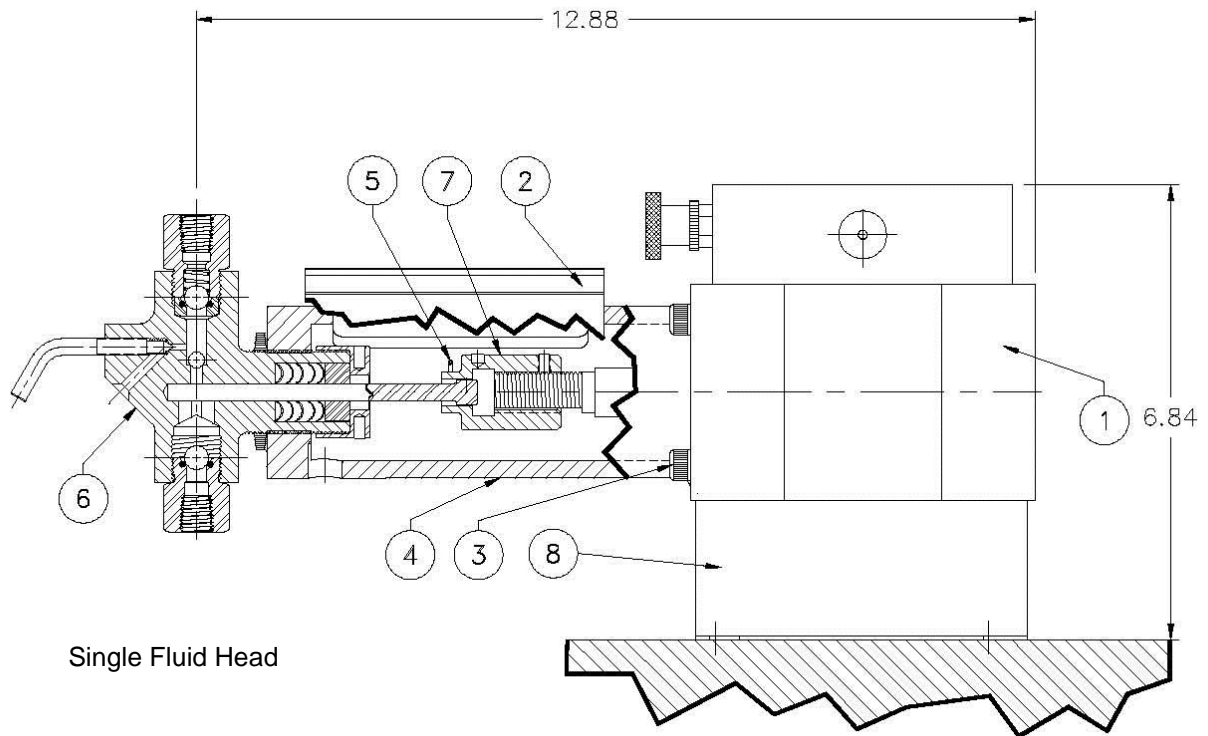

Single Fluid Head

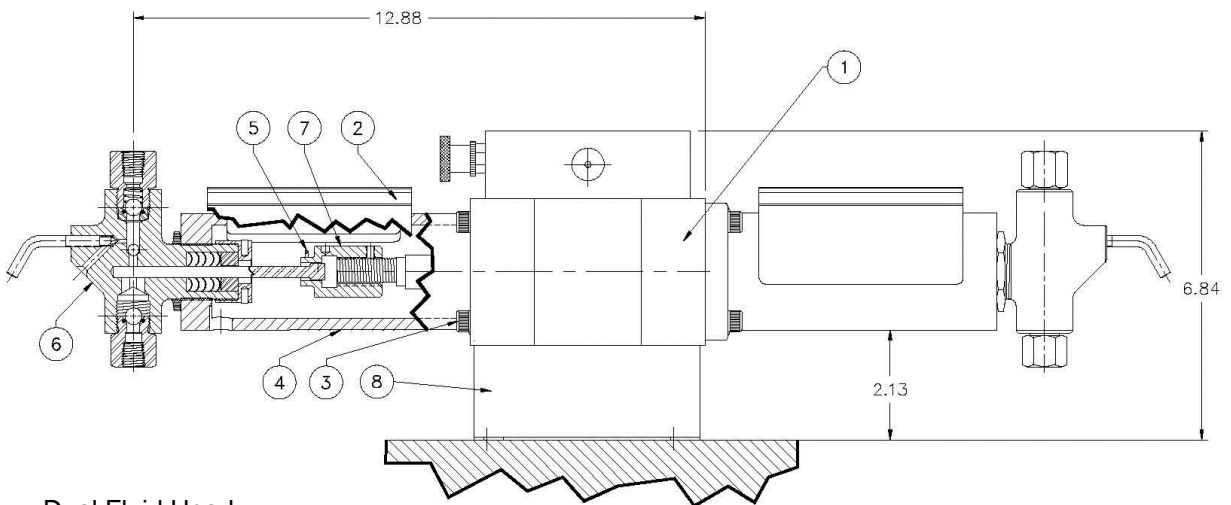

Dual Fluid Head

Figure 1: CVS Low Emission Chemical Injection Pump: Complete Assembly

Parts List

Item	Part No.	No. Req'd	Name	Material
1	CVS-C-2125	1	Power Unit - DASR	----
2	CVS-B-1595	1	Yoke Cover	Plastic
3	CVS-03-1250	4	Socket Head Cap Screw	CS / SST
4	CVS-C-2114	1	Yoke Housing	Aluminum
5	CVS-A-5953	1	Clip	SST
6	CVS-C-2121	1	Fluid End Assembly	Ductile / SST
7	CVS-A-1001	1	Coupler	Aluminum
8	CVS-CA-001	1	Base Plate	Steel

Specifying Pump Order

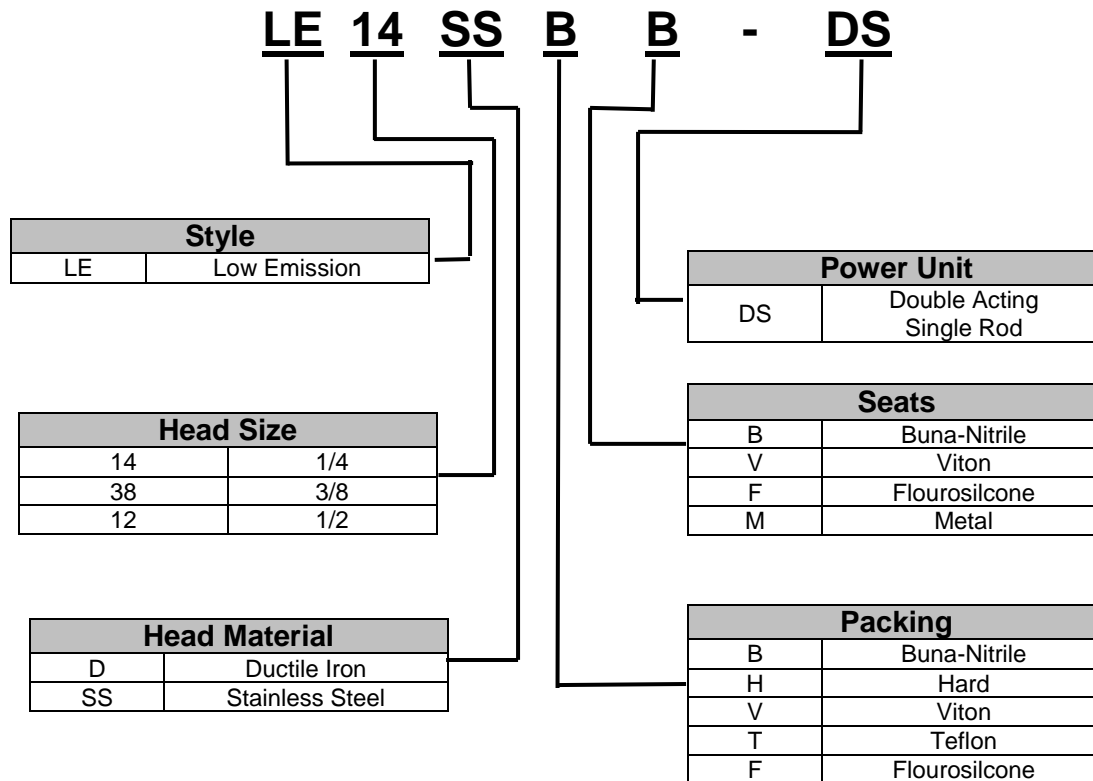

Pump Model Number	Plunger Size Inches	Average Weight Lbs DS
CVS-LE-14	1/4	12.0
CVS-LE-38	3/8	
CVS-LE-12	1/2	

Installation and Operation

The following components should be shipped loose:

- 1/4" Line Check Valve - SS (CVS-A-0675) or 1/4" Line Check Valve - Brass (CVS-A-0676),
- Packing Gland Wrench (CVS-A-0351),
- Priming Valve (CVS-A-1497).

1. Open the shipping container and remove the pump, inspect for visual damage.
2. Blow out and remove debris from supply line before hooking up supply air/gas to inlet. Supply air/gas pressure should be a minimum of 3 psi to a maximum of 150 psi. If the maximum pressure is exceeded, a regulator must be installed in order to reduce and control the pressure to an acceptable level.

Note: The chemical supply inlet (suction port) and discharge ports are 1/4" female connection. The pump should be mounted horizontally with suction ports oriented in the down position.

3. Install the furnished Line Check (CVS-A-0675/0676) before the injection point (Note: the direction of the flow arrow). Connect the discharge line to the 1/4" fNPT in both the line check and the Top Bushing (CVS-A-1496) of the head assembly. Ensure the line is clear of all foreign debris.
4. Install the Priming Valve (CVS-A-1497) into the small threaded hole on the injection head, leaving it partially open.
5. For installation requirements, loosen the lock nut on the fluid end; rotate the power unit to align the control valve to a suitable location. Retighten the lock nut.

Note: The fluid end must be oriented vertically.

6. Install a shut off valve in the air/gas supply line.
7. Connect the 1/4" line to the inlet of the pump control valve.

8. Open the main air/gas supply valve and slowly open the small gas speed control valve. The pump should start automatically. Ensure the suction line is primed with fluid and then test the pump head by opening the Priming Valve. The fluid escaping from the Priming Valve may contain bubbles, as soon as bubbles subside close the Priming Valve for normal operation. Adjust pump for the desired Strokes/Min. and pumping rate. Be sure to keep hands away from moving parts.

Note: As a safety precaution, the media from the weeping holes can be piped to container.

9. The output volume (SPM, stokes per minute) of the pump can be controlled by adjusting the speed control valve from 1 SPM to 60 SPM.
10. Check the packing gland for leakage. If leakage is occurring, use the supplied gland wrench to tighten the gland nut until leak just stops. Do not over tighten the Gland Nut. This may stall the pump or generate excessive wear on the packing and/or plunger.

Maintenance and Troubleshooting

- A. Regularly check for packing leaks, tighten or replace as required.

Note: Ensure the plunger packing is not over tightened, as this may score the plunger and decrease the life span of the packing.

- B. CVS chemical pumps used for alcohol or methanol injection must be fitted with Buna-N O-rings. Pumps used for most chemical injection applications are fitted with flourosilicone O-rings. Refer to chemical manufacturer for material compatibility. O-rings are located in the top seat (CVS-B-0737) and bottom seat (CVS-B-0736). Refer to manufacturer specifications for elastomer sealing fluid compatibilities.
- C. If the pump fails to stroke;
- Check to see if air/gas supply is available – Ensure supply pressure is high enough to overcome the discharge pressure
 - Check to see if packing has been over tightened. If this is the case, replace as required.
 - If the power unit fails;
 - Disconnect air/gas supply and bleed off pressure.
 - Remove drive clip from plunger adaptor.
 - Remove the cap screws that mount the yoke housing to the power unit. Set aside the yoke housing(s) c/w fluid end.
 - Unscrew the plunger adaptors from the power unit rod ends and set aside.
 - Replace the power unit, thread the plunger adaptor(s) onto the rod end(s), attach the yoke housing(s) c/w fluid end(s) with the cap screws, and install the drive clip.
 - Reconnect air gas supply line and set to desired strokes per minute.
- D. If no air/gas venting, check the supply pressure (optimum pressures 3psi – 150psi Max). Erratic changes in pressure may cause the pump to stall.
- E. If pump stalls in forward discharge position, shut off air/gas supply. Check if packing gland nut is over tightened. Readjust packing as required.

- F. If the pump is running, but not pumping, the injection head could be air locked. Open the priming valve and bleed off fluid until no bubbles are present. If still not pumping, the O-ring in the bottom seat may have failed and needs replacing.

Start Up

- Ensure all piping and tubing have been properly connected.
- Determine the number of strokes/min. required to achieve desired injection flowrate (See Technical Data).
- Open air/gas supply to start unit and adjust the speed control valve to desired strokes/min.
- Crack open the Priming Valve to ensure pump action, and that unit is not airlocked.
- Inspect packing and connections for leakage.

Parts List: Injector Head

Pump Model Numbers			CVS-LE-14		CVS-LE-38		CVS-LE-12	
Item	Description	Material	Ductile w/SST Trim	All SST Trim	Ductile w/SST Trim	All SST Trim	Ductile w/SST Trim	All SST Trim
	HEAD ASSY. NO.		CVS-LE-0166	CVS-LE-0755	CVS-LE-0203	CVS-LE-0756	CVS-LE-0496	CVS-LE-0732
1	Body		CVS-C-0275	CVS-C-0291	CVS-C-0276	CVS-C-0425	CVS-C-0272	CVS-C-0349
2*	Plunger	17-4PH	CVS-A-6269	CVS-A-6269	CVS-A-6270	CVS-A-6270	CVS-A-6271	CVS-A-6271
	Plunger, Cryo-Treated				CVS-A-1745/CT	CVS-A-1745/CT		
3	Plunger Packing Gland	303 SST	CVS-A-1463	CVS-A-1463	CVS-A-0957	CVS-A-0957	CVS-A-1219	CVS-A-1219
4*	Plunger Packing** (See table below for max. discharge press.)	Buna-N Hard Viton Teflon Flourosilicone	CVS-A-1461	CVS-A-1461	CVS-A-1456	CVS-A-1456	CVS-A-0959	CVS-A-0959
			CVS-A-2295	CVS-A-2295	CVS-A-1875	CVS-A-1875	CVS-A-1874	CVS-A-1874
			CVS-A-4102	CVS-A-4102	CVS-A-4101	CVS-A-4101	CVS-A-4103	CVS-A-4103
			CVS-A-1642	CVS-A-1642	CVS-A-1234	CVS-A-1234	CVS-A-1012	CVS-A-1012
			CVS-A-1461/FS	CVS-A-1461/FS	CVS-A-1456/FS	CVS-A-1456/FS	CVS-A-0959/FS	CVS-A-0959/FS
5*	O-Ring, Suction & discharge (included in items 9 & 14)	Buna-N Viton Flourosilicone	CVS-A-0479 CVS-A-2580 CVS-A-0479/FS	CVS-A-0479 CVS-A-2580 CVS-A-0479/FS	CVS-A-0479 CVS-A-2580 CVS-A-0479/FS	CVS-A-0479 CVS-A-2580 CVS-A-0479/FS	CVS-A-0479 CVS-A-2580 CVS-A-0479/FS	CVS-A-0479 CVS-A-2580 CVS-A-0479/FS
6	Top Bushing	302 SST	CVS-A-1496	CVS-A-1496	CVS-A-1496	CVS-A-1496	CVS-A-1496	CVS-A-1496
7*	Spring	316 SST	CVS-A-0077	CVS-A-0077	CVS-A-0077	CVS-A-0077	CVS-A-0077	CVS-A-0077
8*	3/8" SST Ball	316 SST	CVS-A-0054	CVS-A-0054	CVS-A-0054	CVS-A-0054	CVS-A-0054	CVS-A-0054
9*	Top Seat Assembly	303 SST	CVS-B-0737	CVS-B-0737	CVS-B-0737	CVS-B-0737	CVS-B-0737	CVS-B-0737
	Top Seat Assembly (Metal to Metal)		CVS-A-0806	CVS-A-0806	CVS-A-0806	CVS-A-0806	CVS-A-0806	CVS-A-0806
10*	1/4" SST Ball	316 SST	CVS-A-0126	CVS-A-0126	CVS-A-0126	CVS-A-0126	CVS-A-0126	CVS-A-0126
11	Priming Valve	303 SST	CVS-A-1497	CVS-A-1497	CVS-A-1497	CVS-A-1497	CVS-A-1497	CVS-A-1497
12	Plunger Pkg. Gland Nut	303 SST	CVS-A-4104	CVS-A-4104	CVS-A-4104	CVS-A-4104	CVS-A-4104	CVS-A-4104
13*	Suction Ball - 3/8"	316 SST	CVS-A-0054	CVS-A-0054	CVS-A-0054	CVS-A-0054	CVS-A-0054	CVS-A-0054
	Suction Ball - 1/2" (use with CVS-A-0771 metal to metal bottom seat only)		CVS-A-0053	CVS-A-0053	CVS-A-0053	CVS-A-0053	CVS-A-0053	CVS-A-0053
14*	Bottom Seat	303 SST	CVS-B-0736	CVS-B-0736	CVS-B-0736	CVS-B-0736	CVS-B-0736	CVS-B-0736
	Bottom Seat Metal to Metal (use with CVS-A-0053 1/2" ball only)		CVS-A-0771	CVS-A-0771	CVS-A-0771	CVS-A-0771	CVS-A-0771	CVS-A-0771
15	Locknut	Brass	CVS-A-0225	CVS-A-0225	CVS-A-0225	CVS-A-0225	CVS-A-0225	CVS-A-0225

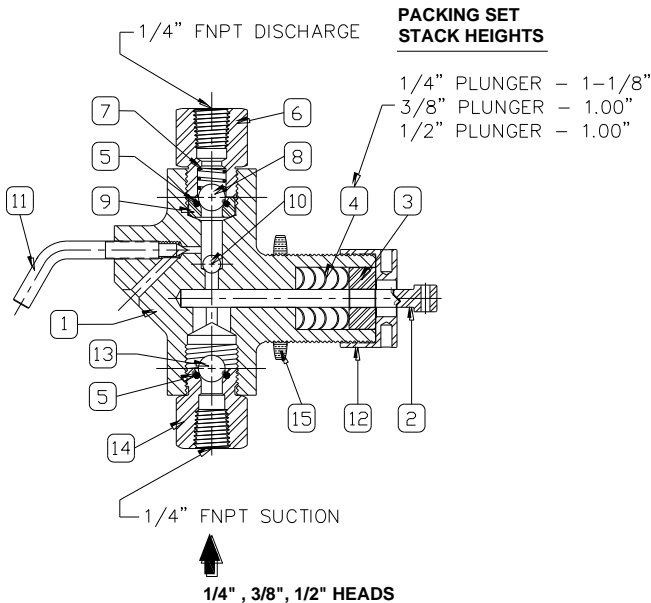

Material	Pressure, PSIG		
	1/4"	3/8"	1/2"
Buna-N	1500	1500	1500
Hard	6000	6000	3500
Viton	3500	3500	3500
Teflon	1500	1500	1500
Flouro	1500	1500	1500

Power end to Fluid end Ratio	
Plunger Size Inches	Operating Ratio Fluid /Gas
1/4"	750:1
3/8"	300:1
1/2"	180:1

VITON® is a registered trademark of Dupont Dow Elastomers
 TEFLON® is a registered trademark of the Dupont Company

Figure 2: CVS Low Emission Chemical Injection Pump: Injector Head Assembly

Technical Data

Pump Capacity (Max Supply Pressure 145 PSI)

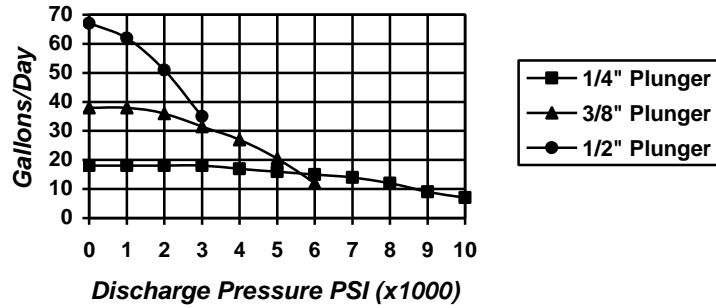

Gallons per Stroke

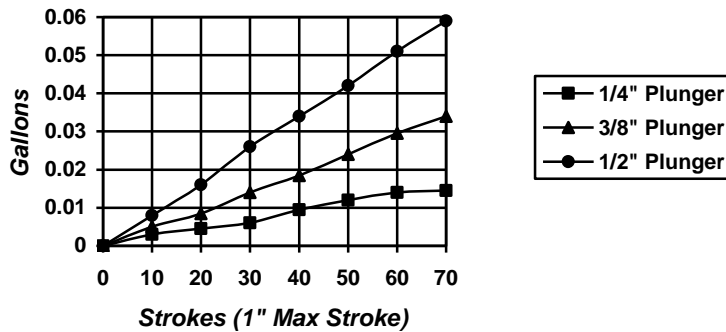

Gas Consumption

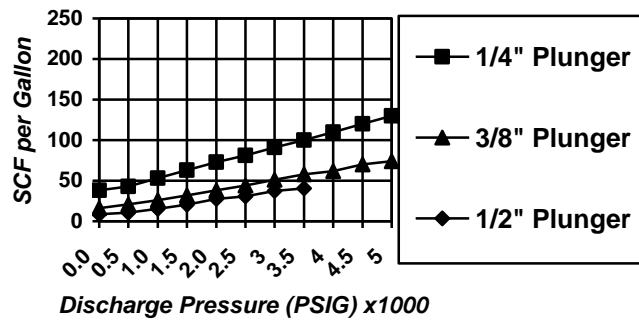

Model No.	Plunger Size	Max Discharge		Max Volume		Min Volume	
		PSI	BARS	GPD	LPD	GPD	LPD
CVS-LE-14	1/4"	10,000	690	14.5	55	.2	.75
CVS-LE-38	3/8"	6,000	414	32	121	.6	2.27
CVS-LE-12	1/2"	3,500	241	62	235	1.1	4.16

CVS Controls Ltd. strives for the highest levels of quality and accuracy. The information included in this publication is presented for informational purposes only. CVS Controls Ltd. reserves the right to modify or change, and improve design, process, and specifications without written notice. Under no circumstance is the information contained to be interpreted to be a guarantee/warranty with regard to our products or services, applicability or use. Selection, use and maintenance are the sole responsibility of the end user and purchaser. CVS Controls assumes no liability for the selection use and maintenance of any product.

CVS

Controls Ltd.

Head Office

3900 – 101 Street
Edmonton, Alberta, Canada T6E 0A5
Office: (780) 437-3055
Fax: (780) 436-5461

Calgary Sales Office

205, 2323 – 32 Avenue NE
Calgary, Alberta, Canada T2E 6Z3
Office: (403) 250-1416
Fax: (403) 291-9487

Website: www.cvs-controls.com

E-Mail: info@cvs-controls.com

Rev 1 May 2016